

P40/P80

(Rod Pusher)

Parts Manual

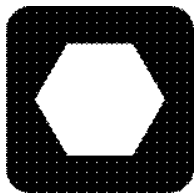

Ditch Witch[®]

P40/P80 **(Rod Pusher)**

ISSUE NO. 15PL-08/11

For Replacement Copy Order **P/N 050-684**

This manual contains information concerning the following models:
P40/P80 (Rod Pusher)

Copyright 2004, 2011 by The Charles Machine Works, Inc.

 **Ditch Witch**, Ditch Witch, CMW, AutoCrowd, Modularmatic, Jet Trac, Roto Witch, Subsite, Fluid Miser, Perma-Soil, Power Pipe, Super Witch, Super Witch II, Pierce Arrow, The Underground, and The Underground Authority Worldwide are registered trademarks of The Charles Machine Works, Inc.

ID0040642

FOREWORD

This manual contains illustrated parts lists to help you select quality ProTech[®] Replacement parts for your Ditch Witch[®] equipment. Using other replacement parts will lessen the productivity of your equipment.

- ◆ Part numbers enclosed in a box are no longer available from The Charles Machine Works, Inc. Your local Ditch Witch dealer may be able to locate the part for you.
- ◆ Footnotes provide more information to help you identify parts shown in the manual.
- ◆ Assembly instructions and Tech Bits articles referenced in footnotes are available through your local Ditch Witch dealer.
- ◆ Description and specifications in this book were current at publication. However, The Charles Machine Works, Inc. reserves the right to improve equipment, so this manual might not reflect the most current improvements.
- ◆ Instructions on recommended equipment use and maintenance are in the Operator's Manual that was shipped with your equipment.

Keep the following in mind when ordering ProTech replacement parts:

- ◆ Specify parts you need by part number and description, not by illustration reference numbers.
- ◆ Have equipment model and serial number on hand to help ensure you get the right parts for your machine whether it's old or new.

Thank you for buying and using Ditch Witch equipment and ProTech replacement parts.

WARRANTY

DW WARRANTY Policy
July, 2005

POLICY 1: DITCH WITCH® EQUIPMENT AND REPLACEMENT PARTS LIMITED WARRANTY POLICY

Subject to the limitation and exclusions herein, free replacement parts will be provided at any authorized Ditch Witch dealership for any Ditch Witch equipment or parts manufactured by The Charles Machine Works, Inc. (CMW) that fail due to a defect in material or workmanship within one (1) year of first commercial use (Exception: 2 years for all SK500 Attachments). Free labor will be provided at any authorized Ditch Witch dealership for installation of parts under this warranty during the first year following "initial commercial" use of the serial numbered Ditch Witch equipment on which it is installed. The customer is responsible for transporting their equipment to an authorized Ditch Witch dealership for all warranty work.

EXCLUSIONS FROM PRODUCT WARRANTY

- All incidental or consequential damages.
- All defects, damages, or injuries caused by misuse, abuse, improper installation, alteration, neglect, or uses other than those for which products were intended.
- All defects, damages, or injuries caused by improper training, operation, or servicing of products in a manner inconsistent with manufacturer's recommendations.
- All engines and engine accessories (these are covered by original manufacturer's warranty).
- Tires, belts, and other parts which are subject to another manufacturer's warranty. (Such warranty will be available to purchaser.)
- ALL IMPLIED WARRANTIES NOT EXPRESSLY STATED HEREIN, INCLUDING ANY WARRANTY OF FITNESS FOR A PARTICULAR PURPOSE AND MERCHANTABILITY.

IF THE PRODUCTS ARE PURCHASED FOR COMMERCIAL PURPOSES, AS DEFINED BY THE UNIFORM COMMERCIAL CODE, THEN THERE ARE NO WARRANTIES WHICH EXTEND BEYOND THE FACE HEREOF AND THERE ARE NO IMPLIED WARRANTIES OF ANY KIND WHICH EXTEND TO A COMMERCIAL BUYER. ALL OTHER PROVISIONS OF THIS LIMITED WARRANTY APPLY INCLUDING THE DUTIES IMPOSED.

Ditch Witch products have been tested to deliver acceptable performance in most conditions. This does not imply they will deliver acceptable performance in all conditions. Therefore, to assure suitability, products should be operated under anticipated working conditions prior to purchase.

Defects will be determined by an inspection within thirty (30) days of the date of failure of the product or part by CMW or its authorized dealer. CMW will provide the location of its inspection facilities or it's nearest authorized dealer upon inquiry. CMW reserves the right to supply remanufactured replacement parts under this warranty as it deems appropriate.

Extended warranties are available upon request from your local Ditch Witch dealer or CMW.

Some states do not allow exclusion or limitation of incidental or consequential damages, so the above limitation or exclusion may not apply. Further, some states do not allow exclusion of or limitation of how long an implied warranty lasts, so the above limitation may not apply. This limited warranty gives product owner specific legal rights and the product owner may also have other rights which vary from state to state.

For information regarding this limited warranty, contact CMW's Product Support Department, P.O. Box 66, Perry, OK 73077-0066, or contact your local Ditch Witch dealer.

CONTENTS

Decals

Decal Location - P40/P80	8
--------------------------------	---

Frame Components

Back Brace	12
Drive Rod Pusher - P40/P80.....	22
Drive Rod Pusher - Trench Box	20
Power Pack Support	36
Rod Rack	38
Storage Box - Early Style	34
Storage Box - S2A/S5A	32
T-Bar	14
Tool Box - Early Style	30
Trailer Mount	26
Trailer Mount - Early Style	24
Trench Box	16
Trench Box Extension	18
Trench Box Trailer Mounts	28

Hydraulics

Cylinder Drive Rod - P40	52
Cylinder Drive Rod - P80 - Begins	54
Cylinder Drive Rod - P80 - Ends.....	56
Drive Hydraulics - Early Style	46
Drive Hydraulics - P40/P80	48
Drive Hydraulics - Present	44
Hydraulic Control Valve	50
Hydraulic Schematic	42
Solenoid Control	58

Electrical

Coil Bracket - Early Style.....	72
Current Transformer.....	68
Electric Diagram - Present.....	70
Grid System Hardware - Present.....	62
Strobe Light	66

Boring Components

Pilot Heads - Beacon/Sondes - P80 - Old	80
Pilot Heads - P40 - New Style	78
Pilot Heads - P40 - Old Style	76
Pilot Heads - P80 - New Style	82
Pulling Tools	88
Pulling Tools Accessories	90
Push Rods - P40	84
Push Rods - P80	86
Rod Grabber - P40/P80	92

Miscellaneous

Bolt/Nut Torque Chart	96
Optional Kits	100
Parts Manual Change Request	101
Related Publications	100
Replacement O-Ring Chart	99
Warranty Registration	104

DECALS

DECAL LOCATION P40 - P80

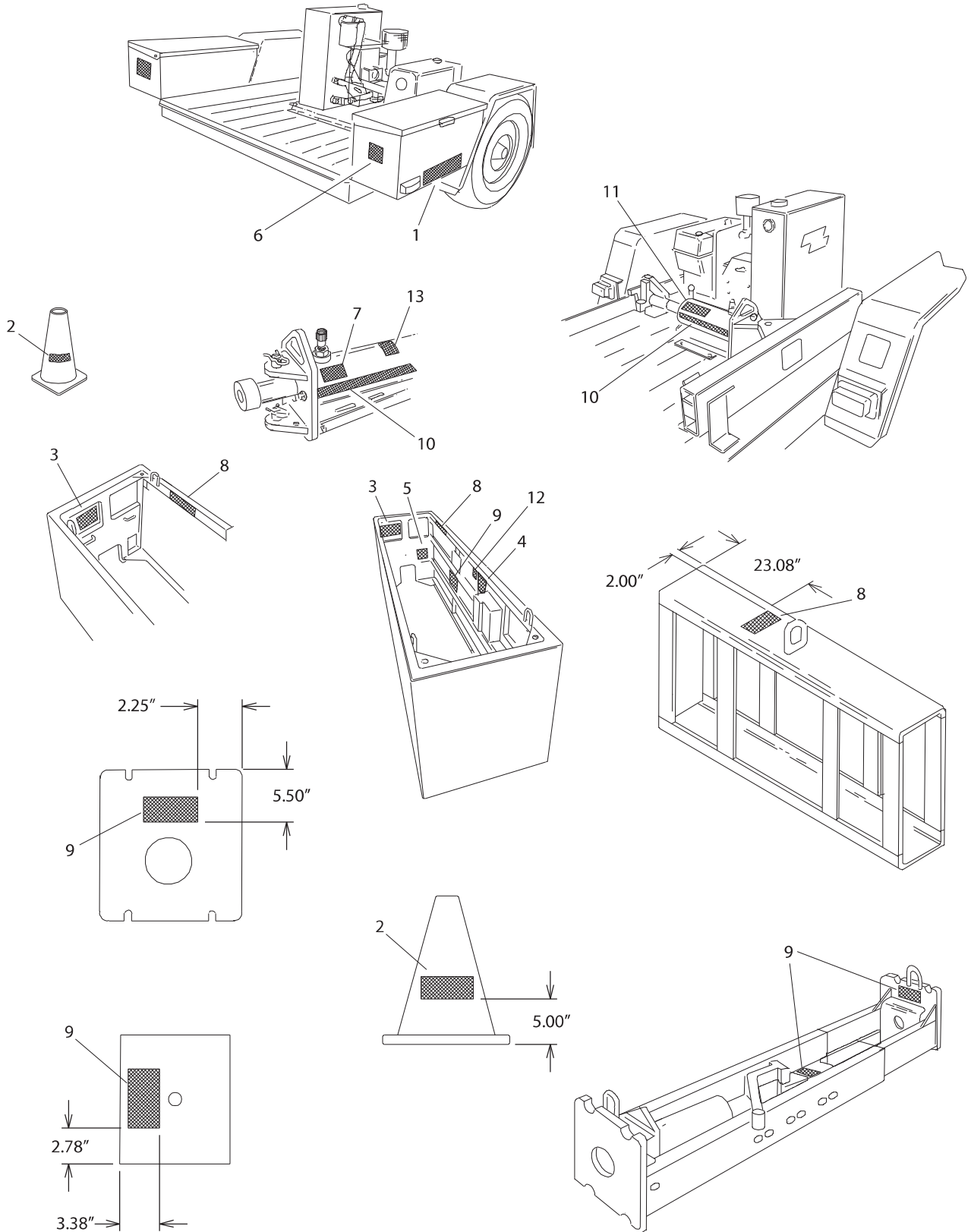

DECAL LOCATION

P40 - P80

REF NO.	PART NUMBER	QTY	DESCRIPTION	REMARKS
	275-573		DECAL KIT - P40 - P80	
I	274-012	2	TP2 MODEL-ID	
	274-013	2	TP5 MODEL-ID	
2	274-049	8	DANGER ELECTROCUTION	
3	274-050	2	WARNING JOBSITE HAZARD	
4	274-079	1	OPERATION INSTRUCTIONS	
5	275-048	1	IMPORATANT SAFETY RULES	
6	275-306	2	DITCH WITCH EMBLEM	
7	275-310	1	DITCH WITCH EMBLEM	
8	275-326	2	WARNING CRUSHING WEIGHT	
9	275-341	2	WARNING SLIDING PARTS	
10	275-430	AR	ACCENT STRIPE (1-7/16")	USE 39"
II	275-446	1	P40 MODEL-ID	
	275-447	1	P80 MDEL-ID	
12	274-724	1	ONE CALL NOTIFICATION	
13	273-009	1	P40-P80 PATENT(S)	

FOOTNOTES

NOTES:

FRAME COMPONENTS

BACK BRACE P40 AND P80

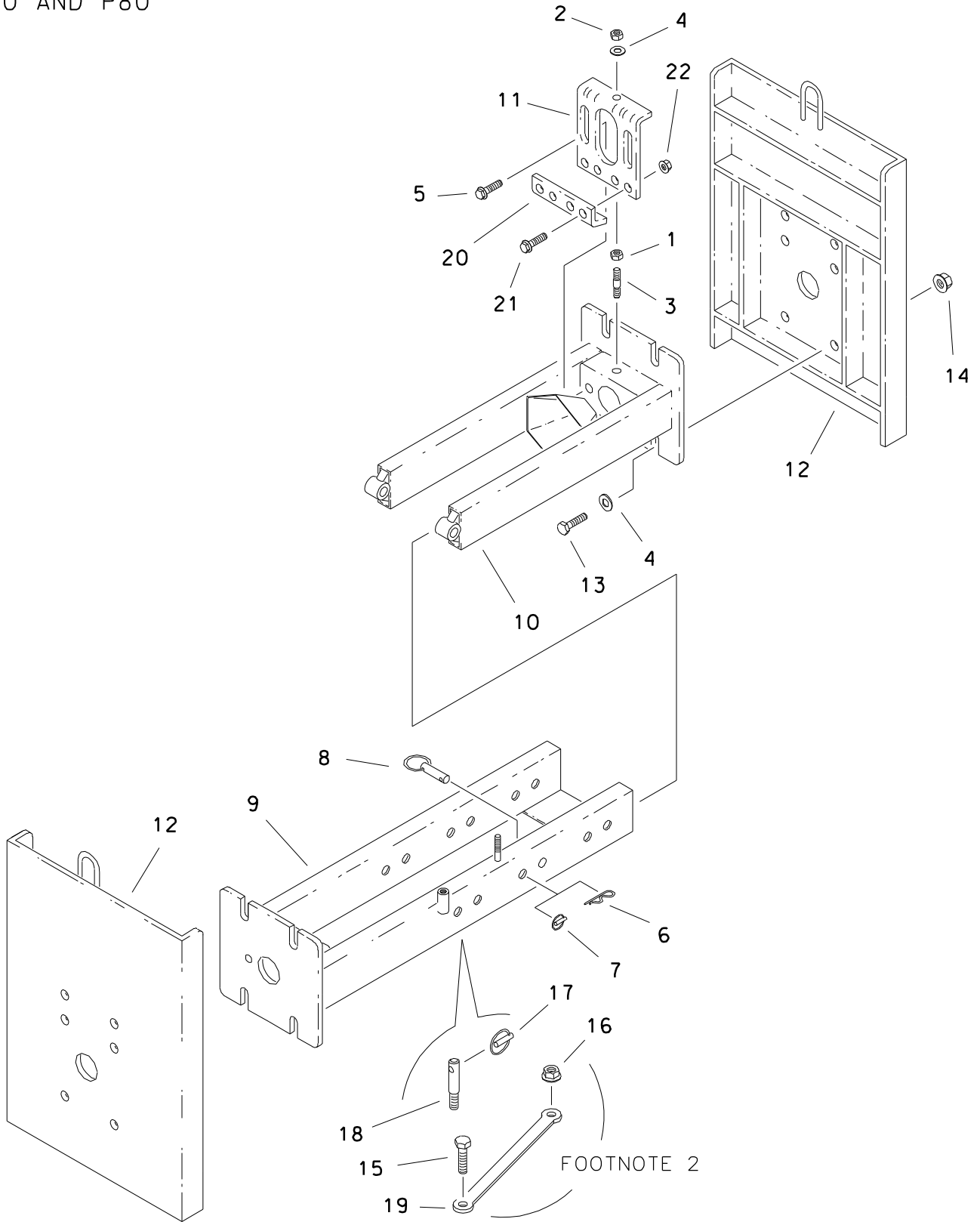

BACK BRACE P40 AND P80

REF NO.	PART NUMBER	QTY	DESCRIPTION	REMARKS
	354-092	1	P40 BACK BRACE ASSEMBLY	INCL REF NO.'S 1 THRU 11, 15, 16, 18 AND 19
	354-107	1	P80 BACK BRACE ASSEMBLY	INCL REF NO.'S 1 THRU 5, 7 THRU 11, 15, 16, 18 & 19
1.	105-310	1	JAM NUT (3/4-NC)	
2.	105-351	1	NUT (3/4-NC)	
3.	105-352	1	SETSCREW (3/4-NC X 5", SQ HD)	
4.	105-384	9	WASHER (3/4")	
5.	105-830	2	FLG LOCK BOLT (1/2-NC X 1-1/4")	
6.	110-128	2	SPRING CLIP PIN (9/64" X 1")	P40
7.	110-228	2	CLIP PIN (7/16" X 1-7/16")	P80
8.	183-328	2	HANDLE PIN (1" OD X 3.5" LG)	P40
	183-292	2	HANDLE PIN (1.375"OD X 5.937"LG)	P80
9.	354-093	1	FRONT BRACE	P40
	354-108	1	FRONT BRACE	P80
10.	354-097	1	REAR BRACE	P40
	354-113	1	REAR BRACE	P80
	354-215	2	FUNNEL HALF	P40
11.	354-102	1	FOOT	P80
	354-221	1	FOOT	INCL REF NO.'S 4, 13 AND 14; SEE FOOTNOTE 1
12.	354-126	2	BACKBRACE SUPPORT	
13.	105-466	8	BLT (3/4-NC X 2-1/2")	
14.	105-340	8	FLANGE LOCKNUT (3/4-NC)	SEE FOOTNOTE 2
15.	105-339	1	BLT (3/4-NC X 2-3/4")	SEE FOOTNOTE 2
16.	105-833	5	FLANGE LOCKNUT (1/2-NC)	SEE FOOTNOTE 2
17.	110-228	1	CLIP PIN (7/16" X 1-7/16")	SEE FOOTNOTE 2
18.	184-024	1	LINKAGE PIN	SEE FOOTNOTE 2
19.	354-130	1	ROTATION DEVICE LINKAGE	P80
20.	354-222	1	FOOT ANGLE	P80
21.	105-831	4	FLG LOCK BOLT (1/2-NC X 1-1/2")	P80
22.	105-833	4	FLANGE LOCKNUT (1/2-NC)	

FOOTNOTES

- 1 - BACK BRACE SUPPORT (REF NO 12) WAS NOT USED ON EARLY MODELS.
- 2 - ROTATION DEVICE (REF NO'S 15 THRU 19) WERE NOT USED ON EARLY MODELS. REFER TO SERVICE BULLETIN 052-719 IF YOU ARE INSTALLING ROTATION DEVICE ON UNITS THAT WERE NOT ORIGINALLY EQUIPPED WITH THEM.

T - BAR P40 AND P80

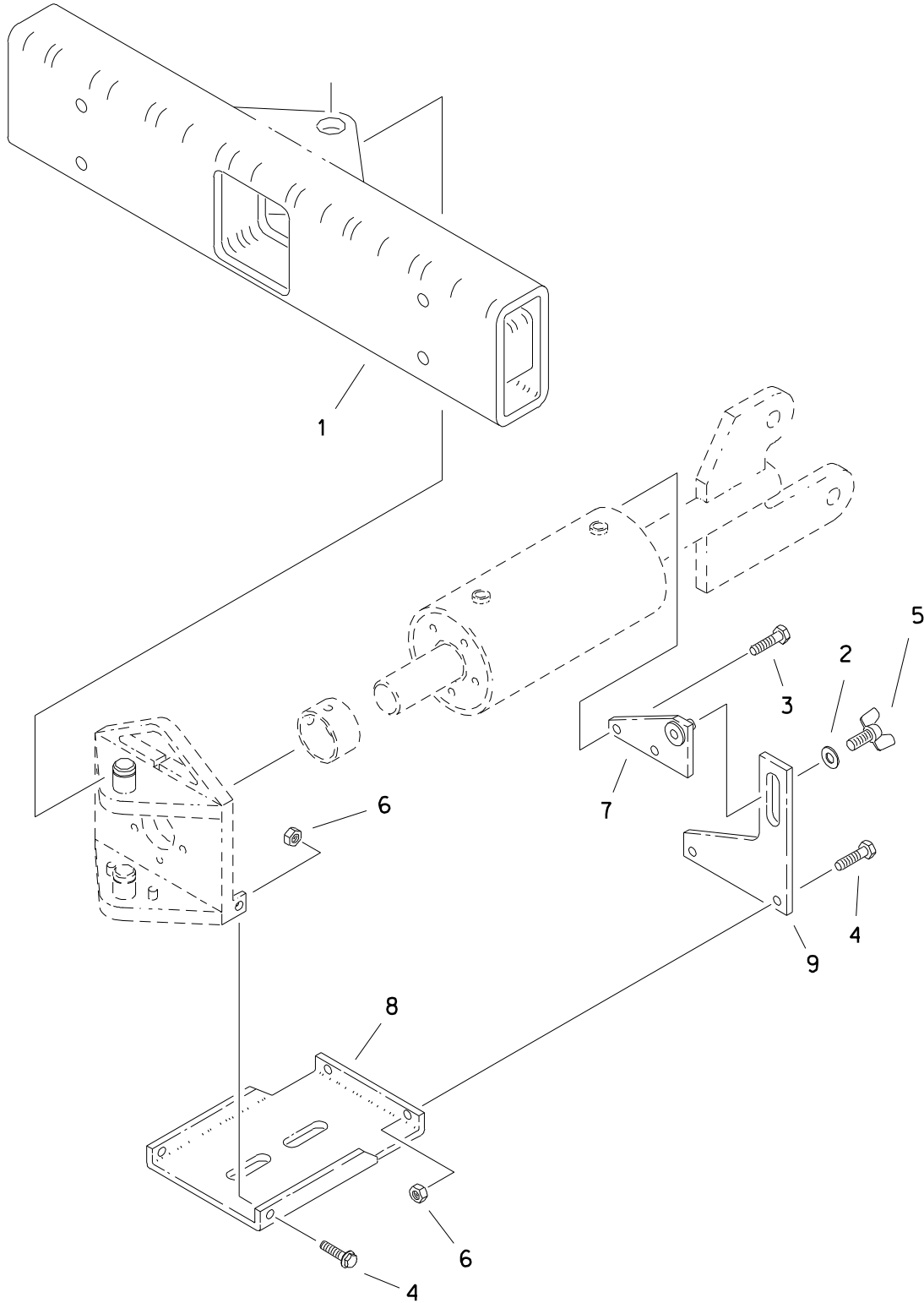

T - BAR P40 AND P80

REF NO.	PART NUMBER	QTY	DESCRIPTION	REMARKS
	354-135		P40 T-BAR ASSY	INCL REF NO.'S 2 THRU 9. SEE FOOTNOTE 1
	354-136		P80 T-BAR ASSY	INCL REF NO.'S 2 THRU 9. SEE FOOTNOTE 1
1.	354-012	1	T-BAR (48")	P40. SEE FOOTNOTE 1
	354-068	1	T-BAR (72")	P80. SEE FOOTNOTE 1
2.	105-071	1	WASHER (1/2")	
3.	105-121	2	BOLT (1/2-NC X 1")	
4.	106-068	4	FLANGE LOCK BOLT (3/8-NC X 1")	
5.	106-072	1	WING BOLT (1/2-NC X 1-1/4")	
6.	105-047	4	LOCKNUT (3/8-NC)	
7.	354-022	1	ADJUSTMENT BRACKET (3" X 4.8")	P40
	354-079	1	ADJUSTMENT BRACKET (4" X 6.38")	P80
8.	354-024	1	CYLINDER BASE (8-1/2" X 17")	P40
	354-076	1	CYLINDER BASE (10.15" X 18.7")	P80
9.	354-025	1	ADJUSTMENT BAR (12")	P40
	354-077	1	ADJUSTMENT BAR (15")	P80

FOOTNOTES

1 - T-BAR (REF NO. 1) MUST BE ORDERED SEPARATELY FROM T-BAR ASSEMBLY.

TRENCH BOX

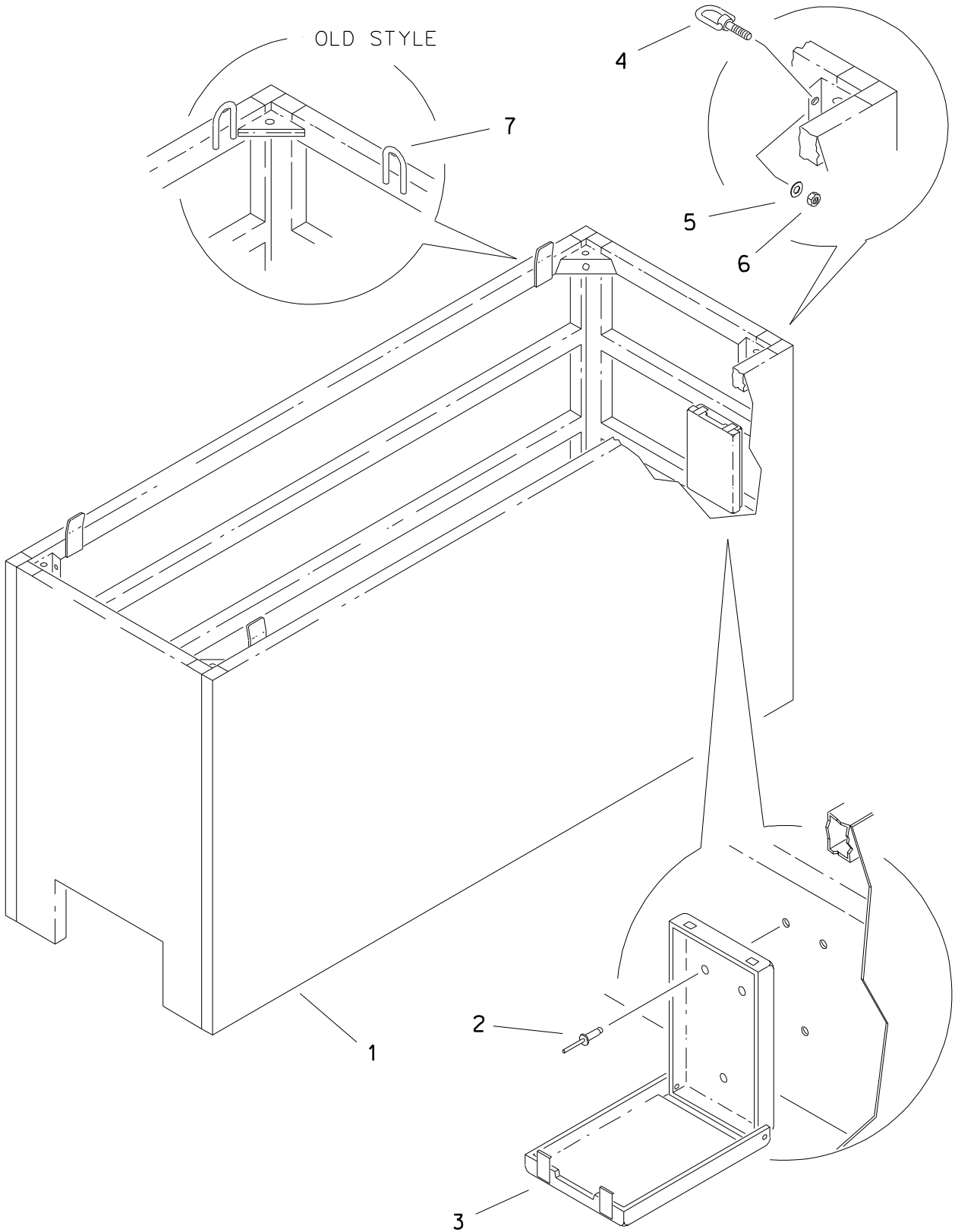

TRENCH BOX

REF NO.	PART NUMBER	QTY	DESCRIPTION	REMARKS
	354-185		TRENCH BOX	INCL REF NO.'S 1 THRU 7
1.	354-186	1	TRENCH BOX	
2.	110-253	3	POP RIVET	
3.	250-622	1	MANUAL COMPARTMENT	
4.	106-420	4	EYE BOLT	
5.	105-363	4	WASHER	
6.	105-478	4	NUT	
7.	599-042	AR	TRENCH BOX LIFT RETROFIT KIT	
	190-468		TRENCH BOX ADAPTER KIT	P80
	190-469		TRENCH BOX ADAPTER KIT	P40

FOOTNOTES

TRENCH BOX EXTENSION

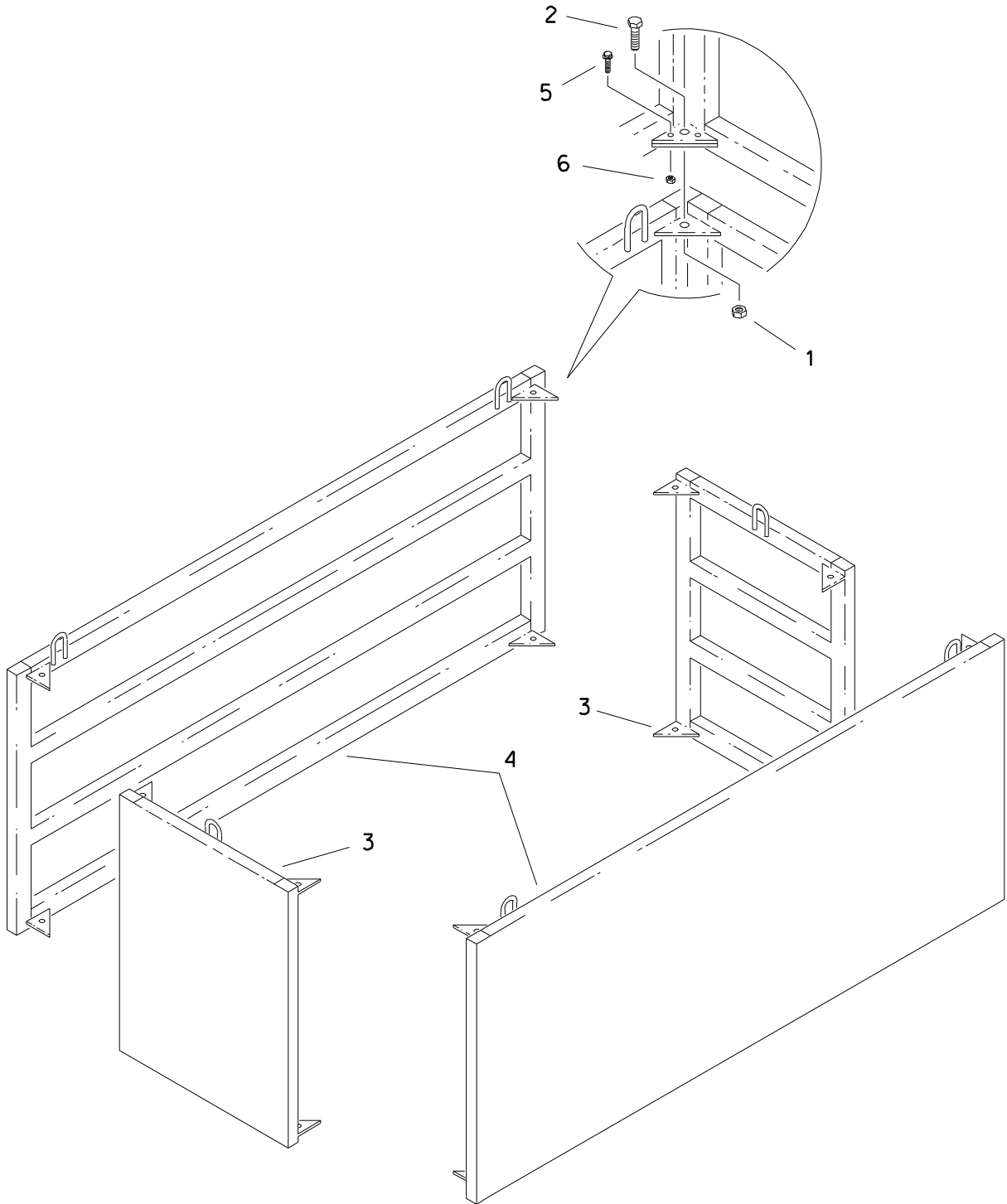

TRENCH BOX EXTENSION

REF NO.	PART NUMBER	QTY	DESCRIPTION	REMARKS
	354-200		TRENCH BOX	INCL REF NO.'S 1 THRU 6
1.	105-367	4	LOCKNUT (1-NC)	
2.	105-368	4	BOLT (1-NC X 5")	
3.	354-179	2	END EXTENSION	
4.	354-184	2	SIDE EXTENSION	
5.	105-830	16	FLANGE LOCK BOLT (1/2-NC X 1-1/4")	
6.	105-833	16	FLANGE LOCKNUT (1/2-NC)	

FOOTNOTES

DRIVE ROD PUSHER P40 AND P80

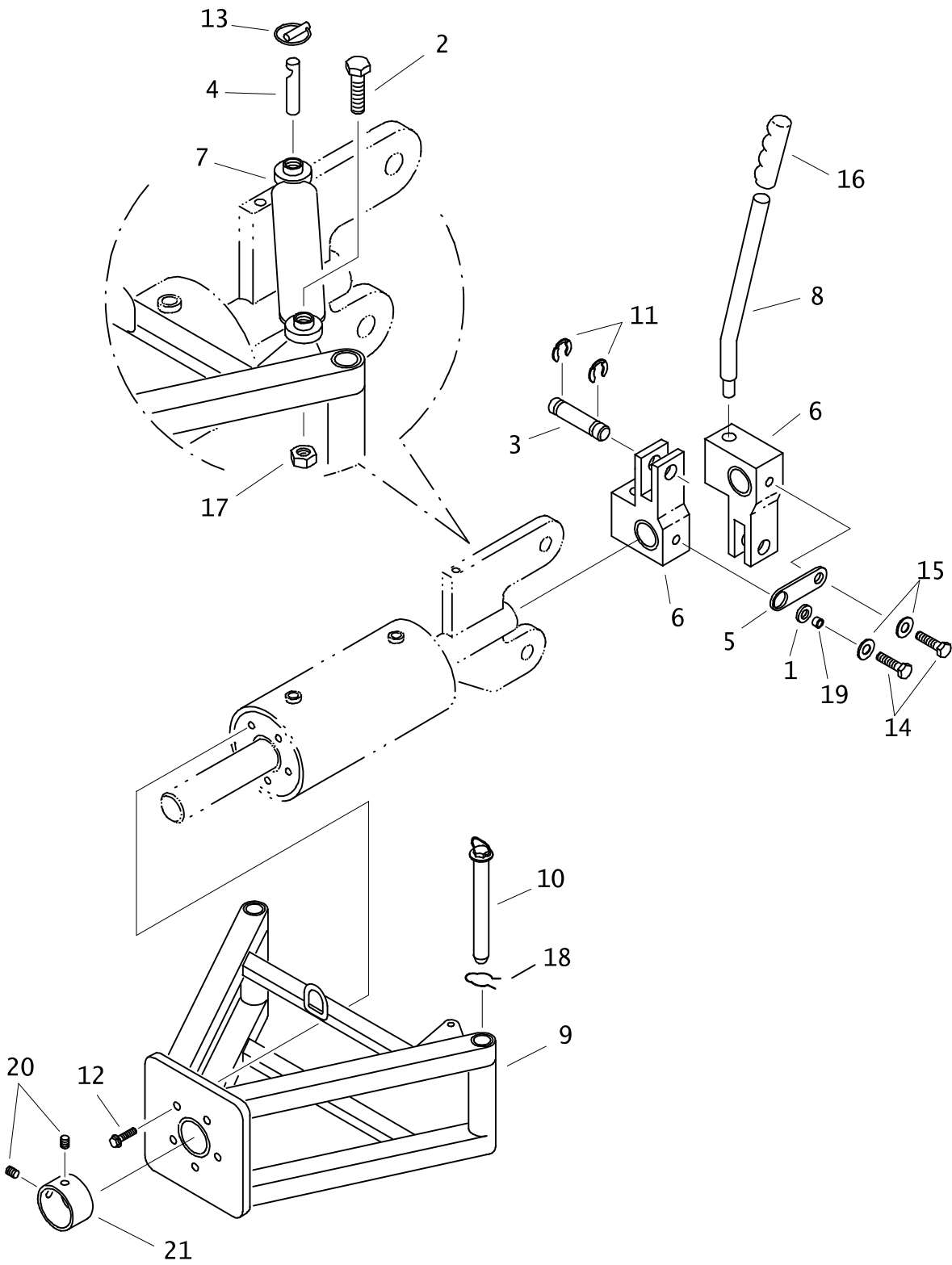

DRIVE ROD PUSHER P40 AND P80

REF NO.	PART NUMBER	QTY	DESCRIPTION	REMARKS
1.	116-283	1	WASHER (.531", RUBBER)	SEE FOOTNOTE 1
	116-443	1	WASHER (1.25", RUBBER)	SEE FOOTNOTE 2
2.	105-339	1	BOLT (3/4-NC X 2-3/4")	
3.	183-517	2	PIN	P40
	183-502	2	PIN	P80
4.	184-024	1	LINKAGE PIN	
5.	354-027	1	STRAP	SEE FOOTNOTE 1
	354-223	1	JAW CONNECTOR STRAP	SEE FOOTNOTE 2
6.	354-021	2	JAW	P40
	354-078	2	JAW	P80
7.	354-130	1	LINKAGE	
8.	361-991	1	HANDLE	
9.	354-171	1	TRUSS FRAME	P40
	354-172	1	TRUSS FRAME	P80
10.	183-676	2	HITCH PIN	
11.	115-499	4	CLIP RING (1")	P40
	115-483	4	CLIP RING (1-1/4")	P80
12.	105-831	5	FLG LK BOLT (1/2-NC X 1-1/2")	P40
	105-337	5	FLG BOLT (5/8-NC X 2")	P80; ENDS WITH S/N CMWP80_90000223.
	106-012	5	FLG BOLT (5/8-NC X 3")	SEE FOOTNOTE 4 - BEGINS WITH S/N CMWP80P90000225.
13.	110-228	1	LYNCH PIN (7/16" X 2")	
14.	106-070	2	SHLD BOLT (1/2" X 3/8", 3/8-NC)	SEE FOOTNOTE 1
	106-216	2	BOLT (3/8-NC X 1", SIL BRZ)	SEE FOOTNOTE 2
15.	105-071	2	WASHER (1/2")	SEE FOOTNOTE 1
	105-069	2	WASHER (.406")	SEE FOOTNOTE 2
16.	110-013	1	GRIP (1", BLK)	
17.	105-340	1	FLG LOCKNUT (3/4-NC)	
18.	110-417	2	SPRING CLIP PIN (.187" X 1")	
19.	184-187	2	BUSHING	
20.	105-702	2	SET SCREW (3/8-NC X 3/8", CUP)	
21.	181-906	1	BUSHING	P40
	181-910	1	BUSHING	P80

NOT SHOWN:

190-468	P80 TRENCH BOX ADPTR KIT	INCL REF NO.'S 2, 4, 7, 9-10, 13 & 17 SEE FOOTNOTE 3
190-469	P40 TRENCH BOX ADPTR KIT	INCL REF NO.'S 2, 4, 7, 9-10, 13 & 17 SEE FOOTNOTE 3
190-479	ESS JAW CONVERSION KIT	INCL REF NO.'S 1, 5, 14-15 & 19 SEE FOOTNOTE 2
354-133	EAR EXTENSION	P40
354-134	EAR EXTENSION	P80

FOOTNOTES:

1. END W/ SN 2H1335 ON P40 AND ENDS W/ SN 2H1308 ON P80.
2. BEGINS W/ SN 2H1336 ON P40 AND BEGINS W/ SN 2H1309 ON P80. TO UPGRADE UNITS PRIOR TO THESE SERIAL NUMBERS ORDER ESID JAWS CONVERSION KIT AND REFER TO INSTALLATION INSTRUCTIONS 050-210.
3. REFER TO INSTALLATION INSTRUCTIONS 050-218.
4. USE WITH 150-3036 CYL., USE LOCTITE 277 OR EQUIVALENT.

NOTE:

DRIVE ROD PUSHER P40 AND P80

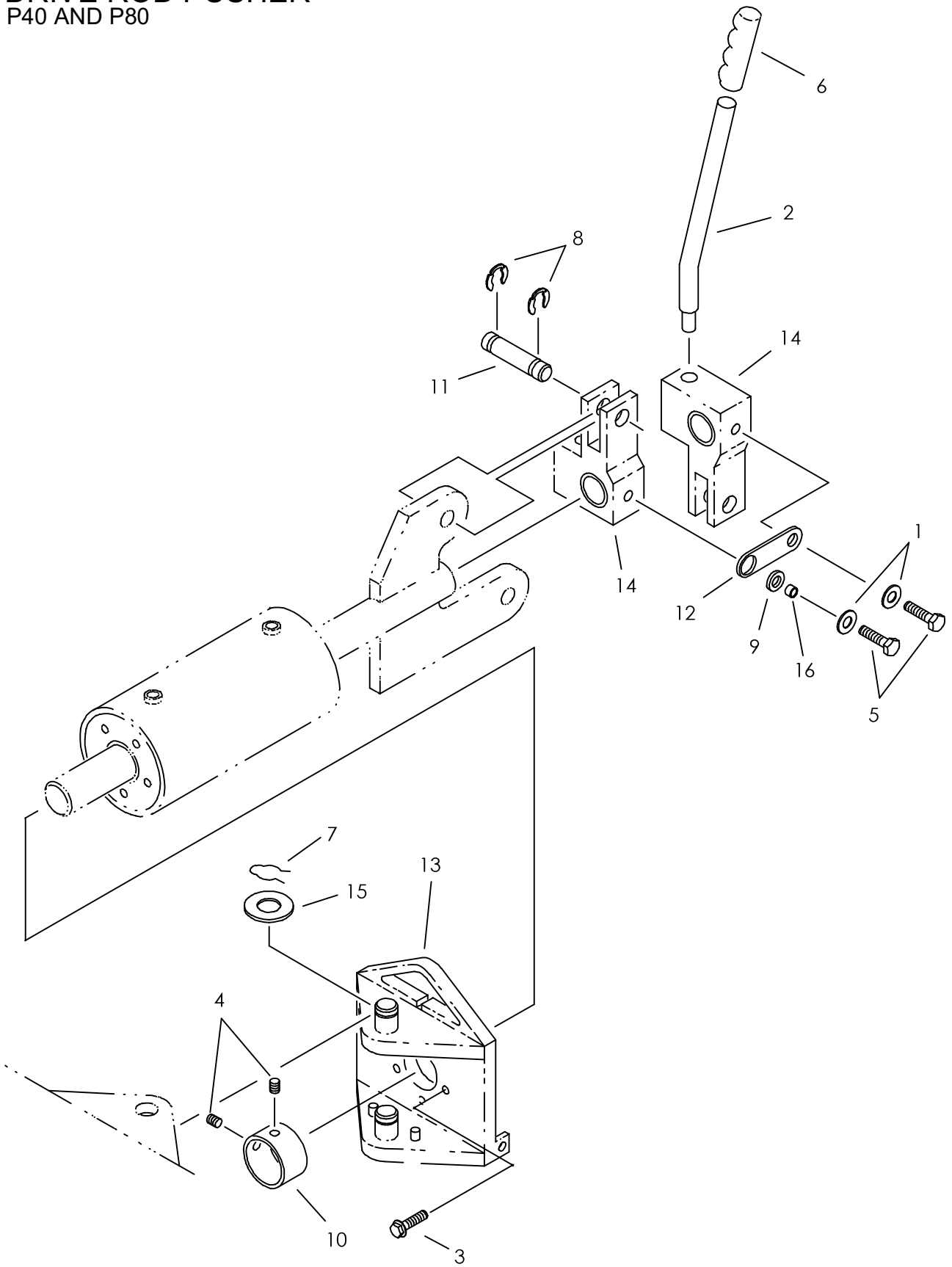

DRIVE ROD PUSHER P40 AND P80

REF NO.	PART NUMBER	QTY	DESCRIPTION	REMARKS
1.	105-071	2	WASHER (1/2")	SEE FOOTNOTE 1
	105-069	2	WASHER (.406")	SEE FOOTNOTE 2
2.	361-991	1	HANDLE	
3.	105-831	5	FLG LK BOLT (1/2-NC X 1-1/2")	P40
	106-012	5	FLG BOLT (5/8-NC X 3")	P80
4.	105-702	2	SET SCREW (3/8-NC X 3/8", CUP)	
5.	106-070	2	SHLD BOLT (1/2" X 3/8", 3/8-NC)	SEE FOOTNOTE 1
	106-216	2	BOLT (3/8-NC X 1", SIL BRZ)	SEE FOOTNOTE 2
6.	110-013	1	GRIP (1", BLK)	
7.	110-417	2	SPRING CLIP PIN (.187" X 1")	
8.	115-499	4	CLIP RING (1")	P40
	115-483	4	CLIP RING (1-1/4")	P80
9.	116-283	1	WASHER (.531", RUBBER)	SEE FOOTNOTE 1
	116-443	1	WASHER (1.25", RUBBER)	SEE FOOTNOTE 2
10.	181-906	1	BUSHING	P40
	181-910	1	BUSHING	P80
11.	183-517	2	PIN	P40
	183-502	2	PIN	P80
12.	354-027	1	STRAP	SEE FOOTNOTE 1
	354-223	1	JAW CONNECTOR STRAP	SEE FOOTNOTE 2
13.	354-018	1	PIVOT	P40
	354-073	1	PIVOT	P80
14.	354-021	2	JAW	P40
	354-078	2	JAW	P80
15.	110-055	2	MACH BUSHING (1-1/4" X 14GA)	
	110-220	2	MACH BUSHING (1-1/2" X 14GA)	
16.	184-187	2	BUSHING	

NOT SHOWN:

190-479 ESS JAW CONVERSION KIT

INCLUDES REF NO.'S 1, 5, 9 & 12. SEE FOOTNOTE 2

FOOTNOTES:

1. ENDS W/ SN 2H1335 ON P40 AND ENDS W/ SN 2H1308 ON P80.
2. BEGINS W/ SN 2H1336 ON P40 AND BEGINS W/ SN 2H1309 ON P80. TO UPGRADE UNITS PRIOR TO THESE SERIAL NUMBERS ORDER ESID JAWS CONVERSION KIT AND REFER TO INSTALLATION INSTRUCTIONS 050-210.

NOTE:

TRAILER MOUNT EARLY STYLE

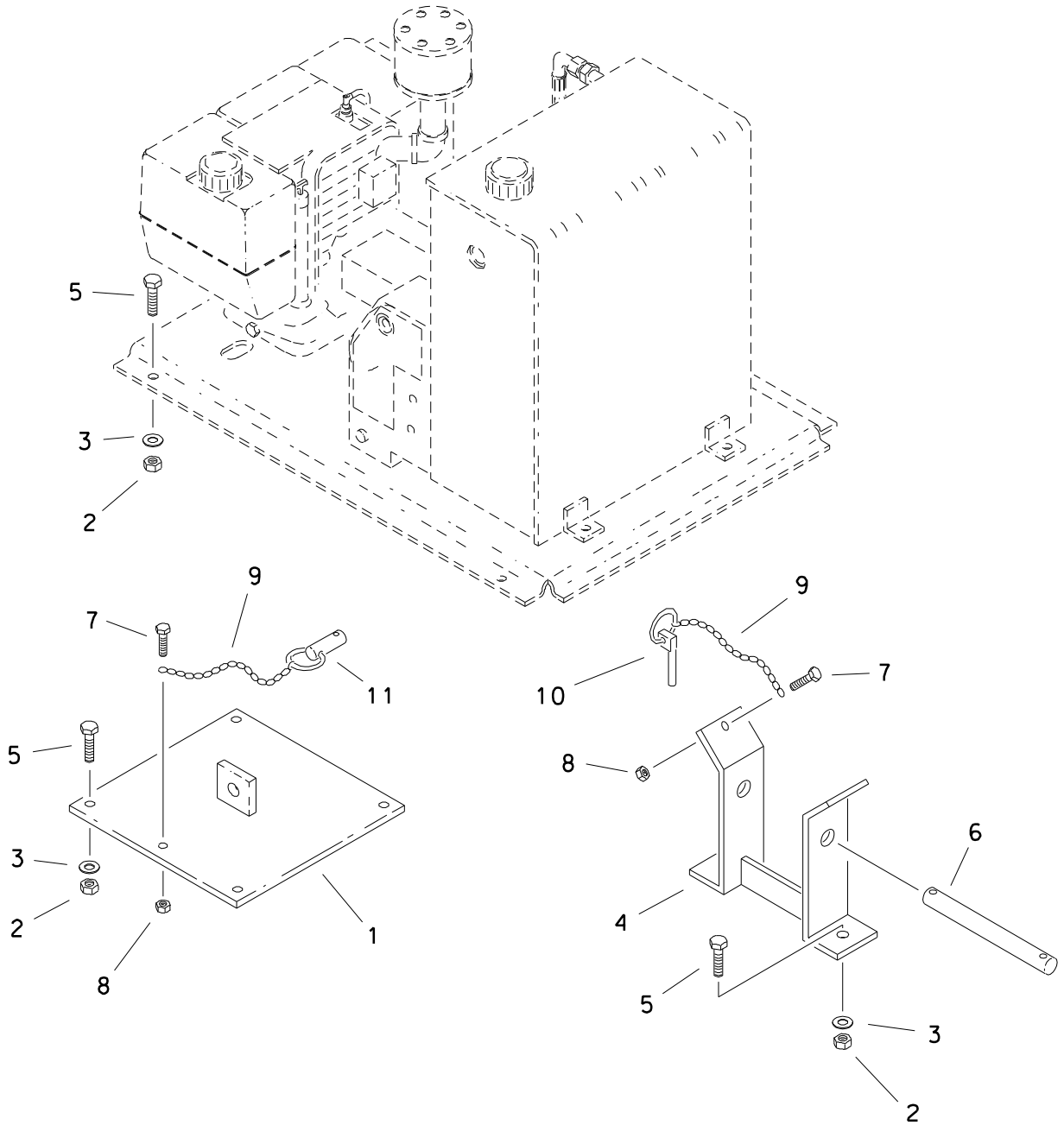

TRAILER MOUNT EARLY STYLE

REF NO.	PART NUMBER	QTY	DESCRIPTION	REMARKS
	190-412		TRAILER ROD PUSHER MOUNT CON. KIT	INCL REF NO.'S 1 THRU 11. SEE FOOTNOTE 1
1.	354-043	1	CYLINDER BRACKET	SEE FOOTNOTE 1
2.	105-065	14	LOCKNUT (1/2-NC)	
3.	105-071	14	WASHER (1/2")	
4.	354-041	2	T-BAR MOUNT BRACKET	SEE FOOTNOTE 1
5.	105-082	14	BOLT (1/2-NC X 2-1/2")	
6.	183-518	2	PIN (0.75" OD X 6.9" LG)	SEE FOOTNOTE 1
7.	105-185	5	BOLT (#10-24 X 1/2", RD SLT HD)	
8.	105-186	5	NUT (#10-24)	
9.	110-109	5	CHAIN (SINGLE JACK #14)	USE 9"
10.	110-228	4	CLIP PIN (7/16" X 1-7/16")	
11.	183-411	1	PULL PIN (0.5" OD X 2.5" LG)	

FOOTNOTES

1 - THESE PARTS ARE NO LONGER AVAILABLE. FOR CURRENT CONVERSION KIT REFER TO PAGE 803-375 "TRAILER MOUNTS".

TRAILER MOUNTS

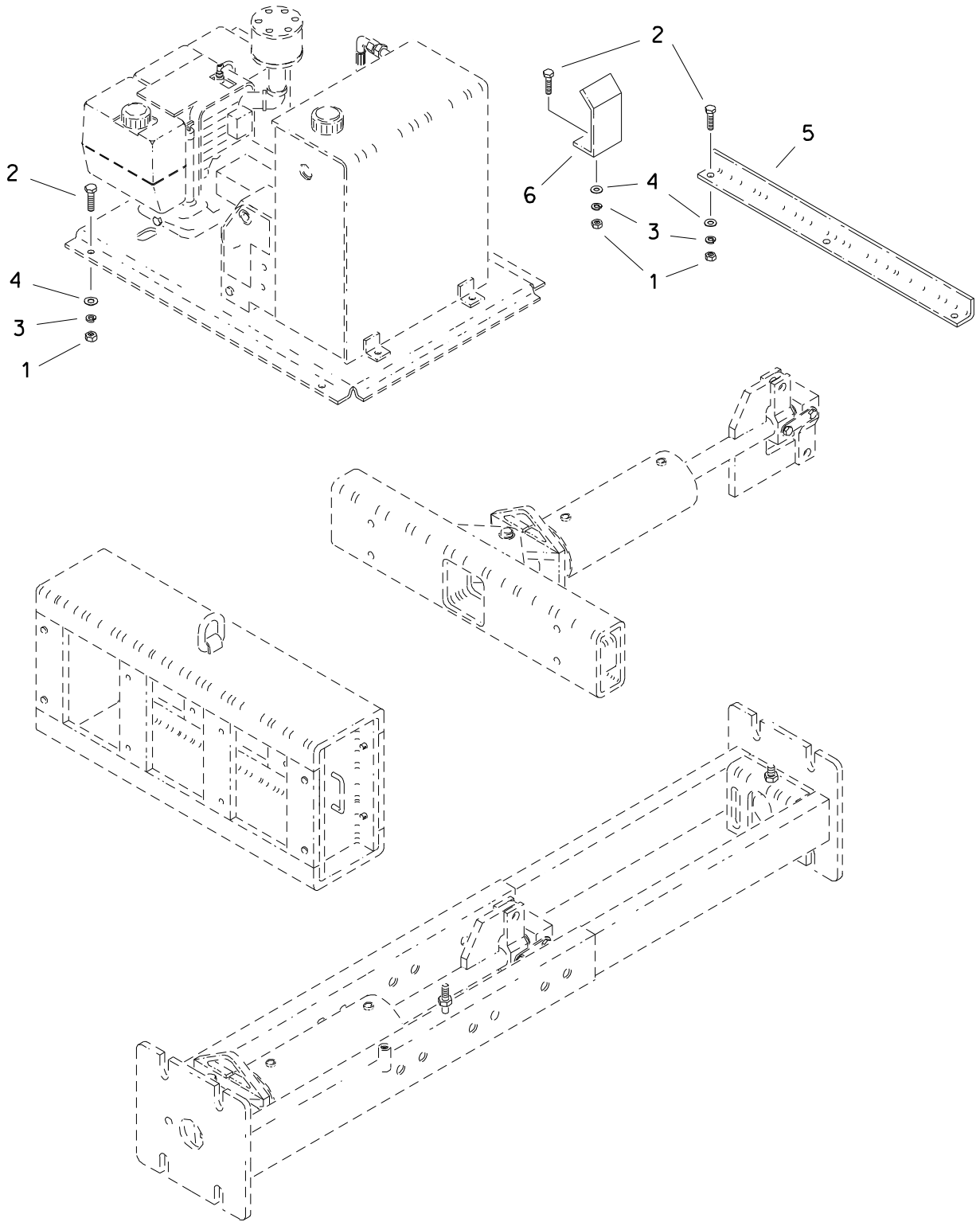

TRAILER MOUNTS

REF NO.	PART NUMBER	QTY	DESCRIPTION	REMARKS
	190-427		TRAILER MOUNT CONVERSION KIT	INCL REF NO.'S 1 THRU 6; SEE FOOTNOTE 2
1.	105-021	21	NUT (1/2-NC)	
2.	105-067	21	BOLT (1/2-NC X 2-3/4")	
3.	105-070	21	LOCK WASHER (1/2")	
4.	105-071	21	WASHER (1/2")	
5.	326-191	2	MOUNT BRACKET	USED ON ROD RACK
6.	326-193	11	MOUNT BRACKET	

NOT SHOWN:

326-129	AR	D-RING	SEE FOOTNOTE 1
326-154	AR	SADDLE	SEE FOOTNOTE 1

FOOTNOTES

- 1 - PARTS NOT INCLUDED WITH KIT AND SHOULD BE ORDERED SEPERATELY.
- 2 - REFER TO INSTALLATION DIAGRAM 050-117.

TRENCH BOX TRAILER MOUNTS

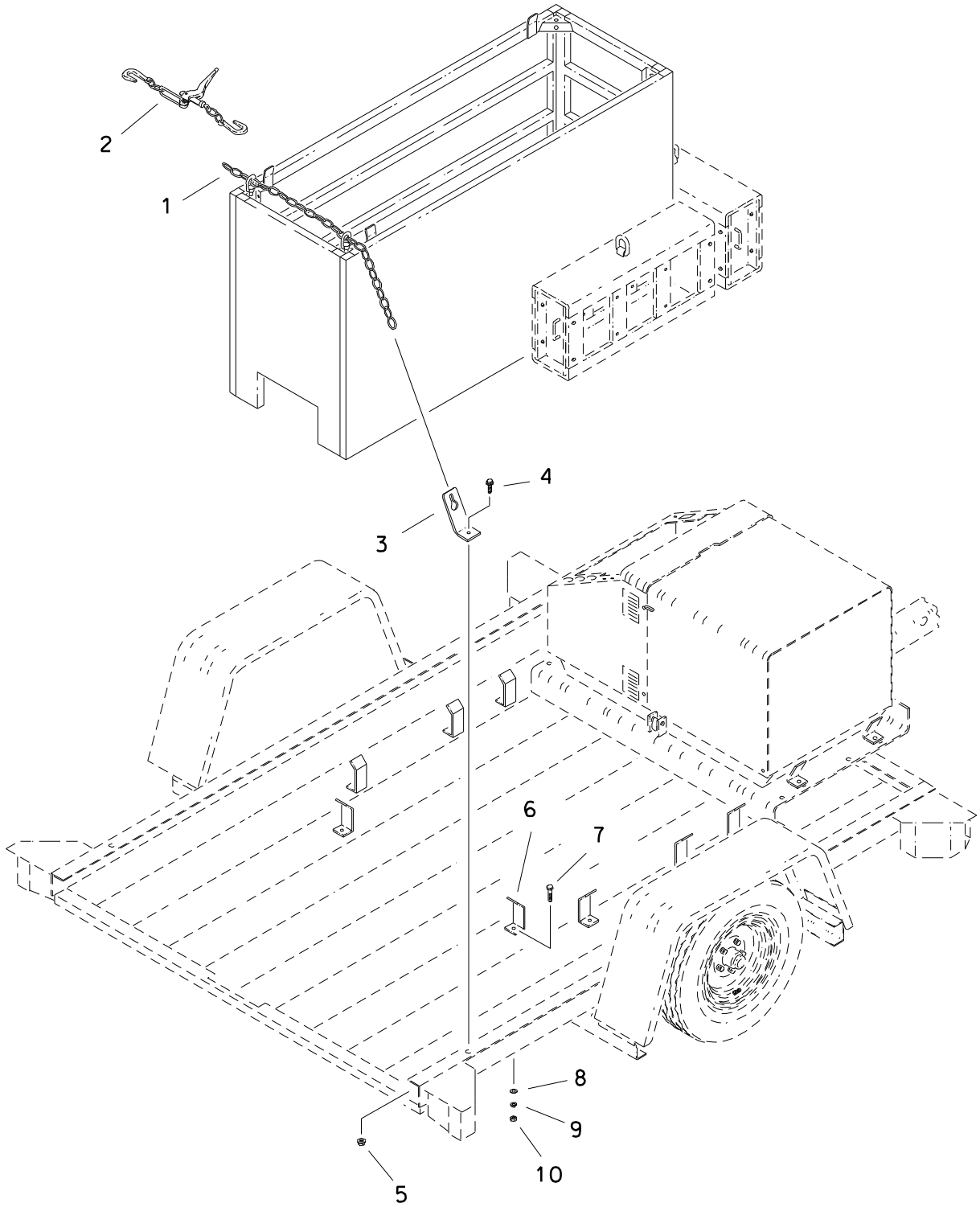

TRENCH BOX TRAILER MOUNTS

REF NO.	PART NUMBER	QTY	DESCRIPTION	REMARKS
1.	110-048	1	CHAIN (5/16")	
2.	110-049	1	CHAIN BOOMER (3/16 X 5/16")	
3.	351-645	2	CHAIN SUPPORT	
4.	105-830	2	FLG LK BOLT (1/2-NC X 1-1/4")	
5.	105-833	2	FLG LOCKNUT (1/2-NC)	
6.	326-193	8	MOUNT BRACKET	
7.	105-067	8	BOLT (1/2-NC X 2-3/4")	
8.	105-071	8	WASHER (1/2")	
9.	105-070	8	LOCK WAhSER (1/2")	
10.	105-021	8	NUT (1/2-NC)	

FOOTNOTES

TOOL BOX
S2A
EARLY STYLE

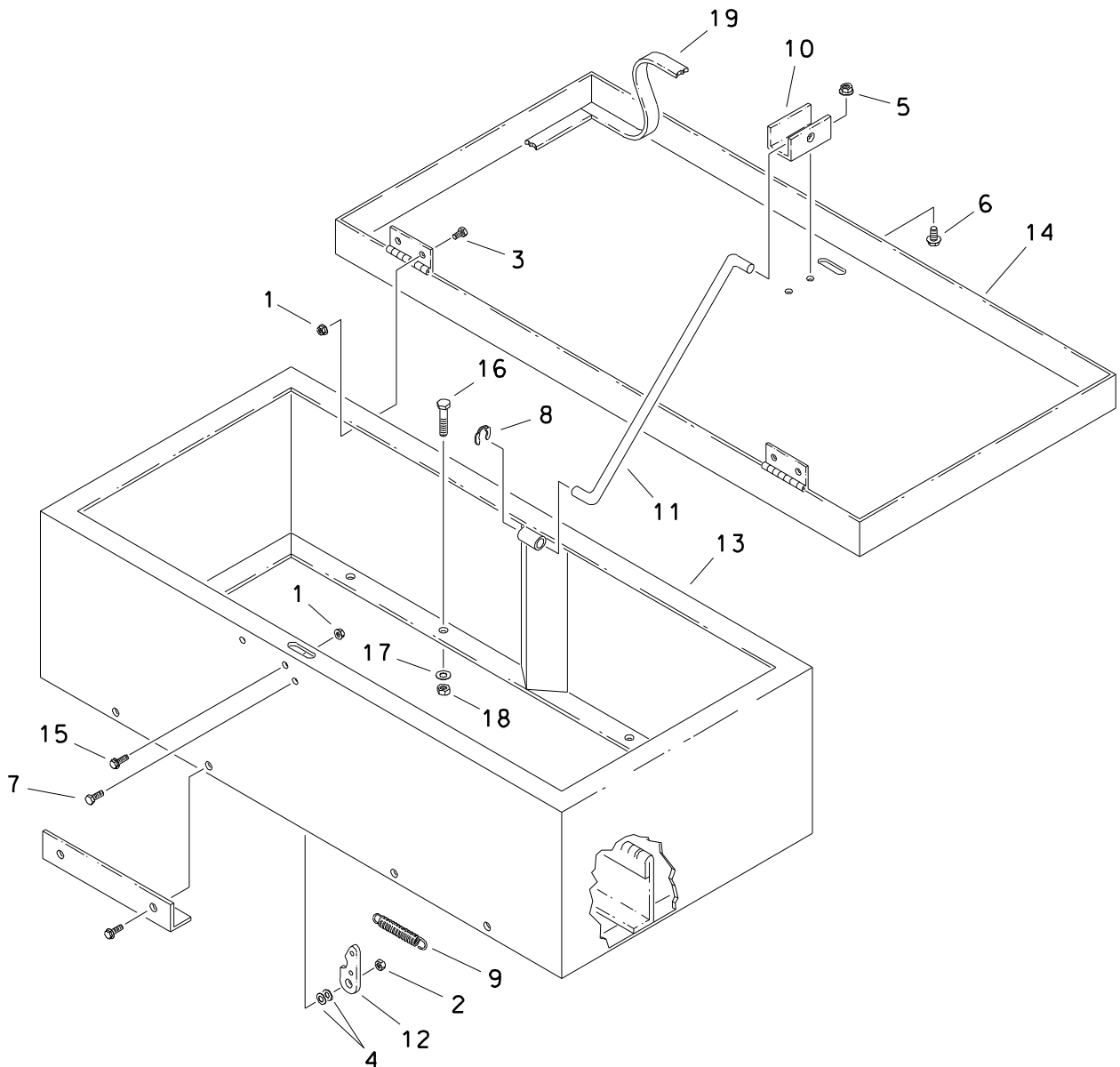

TOOL BOX
S2A
EARLY STYLE

REF NO.	PART NUMBER	QTY	DESCRIPTION	REMARKS
	100-674		TOOL BOX PARTS ASSEMBLY	INCL REF NO.'S 1 THRU 19
1.	105-003	5	FLANGE LOCKNUT (5/16-NC)	
2.	105-089	1	LOCKNUT (5/16-NC)	
3.	105-090	4	BOLT (5/16-NC X 3/4")	
4.	105-117	2	WASHER (5/16")	
5.	105-832	2	FLANGE LOCKNUT (1/4-NC)	
6.	105-836	2	FLANGE LOCK BOLT (1/4-NC X 1/2")	
7.	105-873	1	FLANGE LOCK BOLT (5/16-NC X 1")	
8.	115-477	1	EXTERNAL GRIP RING	
9.	115-556	1	EXTENSION SPRING	
10.	300-787	1	ROD GUIDE	
11.	300-832	1	PROP BAR	
12.	300-834	1	LATCH	
13.	354-034	1	TOOL BOX	
14.	354-035	1	TOOL BOX LID	
15.	501-325	1	FLANGE LOCK BOLT (5/16-NC X 5/6")	
16.	105-075	4	BOLT (3/8-NC X 2")	
17.	105-118	4	WASHER (3/8")	
18.	105-047	4	LOCKNUT (3/8-NC)	
19.	115-399	AR	WEATHER STRIPPING (1/4" X 3/4")	USE 100"

FOOTNOTES

1 - THIS STYLE OF TOOL BOX IS NO LONGER AVAILABLE. REFER TO PAGES ENTITLED "STORAGE BOX"-S2A OR S5A.

STORAGE BOX - S2A, S5A

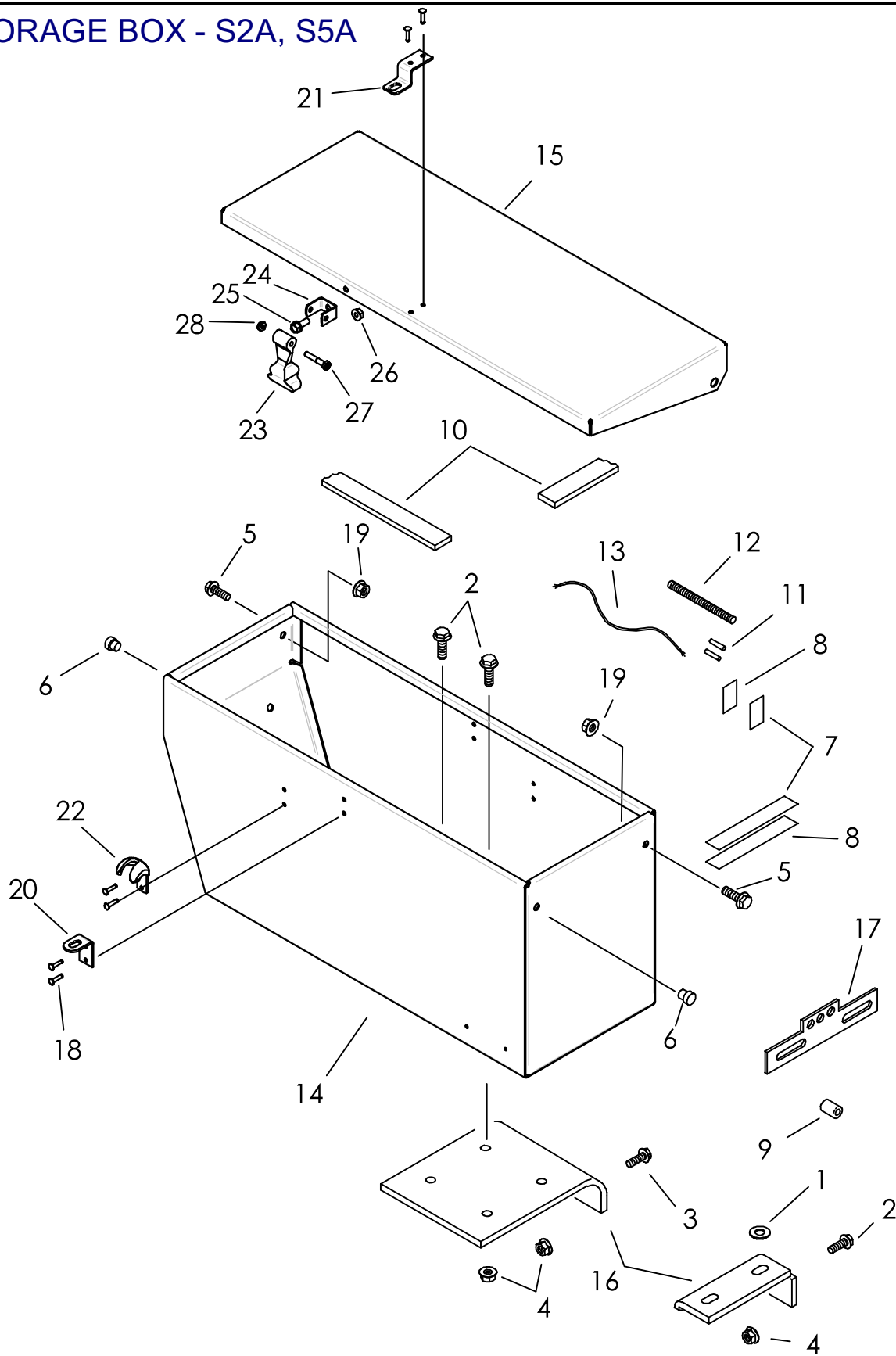

STORAGE BOX - S2A, S5A

REF NO.	PART NUMBER	QTY	DESCRIPTION	REMARKS
	190-425		STORAGE BOX KIT	S2A
	190-426		STORAGE BOX CONVERSION KIT	S5A
	050-192		INSTALLATION DIAGRAM	
1.	105-069	1	WASHER (.406")	S5A, SEE FOOTNOTE 1
2.	105-825	AR	FLG LK BOLT (3/8-NC X 3/4")	(8) S2A / (7) S5A
3.	105-826	2	FLG LK BOLT (3/8-NC X 1")	S2A
4.	105-845	AR	FLG LOCKNUT (3/8-NC)	(10) S2A / (7) S5A
5.	106-070	2	SHLD BLT (1/2" X 3/8", 3/8-NC)	
6.	110-219	AR	HOLE PLUG (3/8")	OBSOLETE (2) S2A / (5) S5A
	115-968	AR	BUTTON PLUG (3/8"-3)	(2) S2A / (5) S5A
7.	110-366	AR	VELCRO STRIP (1", SOLD PER 1")	S2A USE 12"
8.	110-431	AR	VELCRO STRIP (1", SOLD PER 1")	S2A, USE 12"
9.	115-349	1	GROMMET (1/2")	S2A, SEE FOOTNOTE 1
10.	115-399	AR	BULK STRIP (3/4", SOLD PER 1")	S2A, USE 75"
11.	215-478	AR	BUTT CONNECTOR (14-16GA)	(4) S2A / (2) S5A
12.	215-488	AR	FLEX GUARD (3/8", SOLD PER 1")	USE 24", SEE FOOTNOTE 1
13.	215-496	AR	1- WIRE (14 GA, BRN) SOLD PER FT	S5A, SEE FOOTNOTE 1
14.	326-983	1	STORAGE BOX BODY	S2A
	326-987	1	STORAGE BOX BODY	S2A
15.	326-985	1	STORAGE BOX TOP ASS'Y (S2A)	S2A
	326-982	1	STORAGE BOX TOP	S5A
16.	326-188	1	"NS" REAR BRACKET	S5A, REAR STORAGE BRACE, SEE FOOTNOTE 1
17.	360-124	1	S2 S4 T6 T12BW TAG BRACKET	S2A, SEE FOOTNOTE 1
18.	110-449	6	POP RIVET (3/16" X .690")	
19.	105-814	3	FLG LOCKNUT (3/8-NC)	
20.	303-330	1	HASP	
21.	300-5317	1	HASP	
22.	110-223	1	LATCH BRACKET	
23.	110-222	1	HOOD LATCH	
24.	110-224	1	ANCHOR BRACKET	
25.	105-823	1	FLG LK BOLT (5/16-NC X 3/4")	
26.	105-003	1	FLG LOCKNUT (5/16-NC)	
27.	105-818	1	BOLT (1/4-NC X 1-1/2")	
28.	105-085	1	LOCKNUT (1/4-NC)	

NOT SHOWN:

274-012	1	TP 2 MODEL-ID
274-013	1	TPAC 5 MODEL-ID DECAL
275-306	1	DITCH WITCH EMBLEM
275-089	1	STEERING WHEEL PLAQUE

FOOTNOTES:

- PARTS NOT INCLUDED WITH KIT AND SHOULD BE ORDERED SEPARATELY.

NOTE:

STORAGE BOX EARLY STYLE

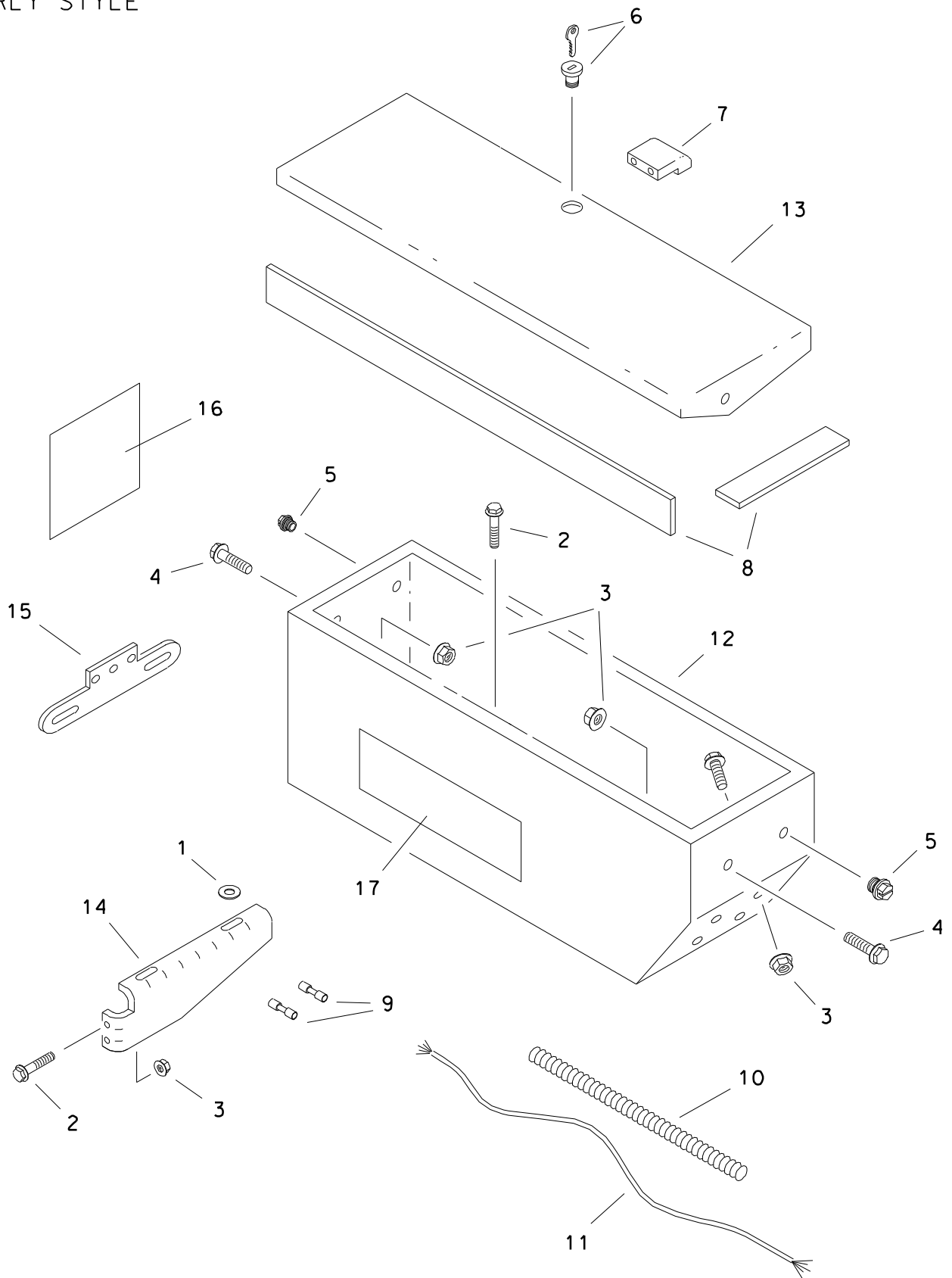

STORAGE BOX EARLY STYLE

REF NO.	PART NUMBER	QTY	DESCRIPTION	REMARKS
	190-426		STORAGE BOX CONVERSION KIT	S5A / TP5
	050-192		INSTALLATION INSTRUCTION	
1.	105-069	1	WASHER (3/8")	SEE FOOTNOTE 1
2.	105-825	7	FLG LCK BOLT (3/8-NC X 3/4")	
3.	105-845	9	FLG LOCKNUT (3/8-NC)	
4.	106-070	2	SHOULDER BOLT (3/8-NC X 3/8")	
5.	110-219	5	HOLE PLUG (3/8")	
	115-968	5	BUTTON PLUG (3/8"-3)	
6.	110-502	1	CAM LOCK (INCL KEY)	
	N/A		KEY (SINGLE)	
7.	110-503	1	PULL HANDLE (INCL SCREWS)	
	N/A		SCREWS (PAIR)	
8.	115-399	AR	WEATHER STRIPPING	USE 113"
9.	215-478	2	BUTT CONNECTOR (16 GA)	
10.	215-488	AR	FLEX GUARD	USE 24"; SEE FOOTNOTE 1
11.	215-496	AR	1-WIRE (14 GA)	USE 50"; SEE FOOTNOTE 1
12.	326-170	1	BOX	
13.	326-180	1	LID	
14.	326-188	1	REAR BRACKET	SEE FOOTNOTE 1
15.	360-124	1	TAG BRACKET	SEE FOOTNOTE 1
16.	274-013	1	TRANS PAC 5 MODEL-ID DECAL	
17.	275-306	1	DITCH WITCH EMBLEM DECAL	OPTIONAL STORAGE BOX

FOOTNOTES

1 - PARTS NOT INCLUDED WITH KIT AND SHOULD BE ORDERED SEPARATELY

POWER PACK SUPPORT

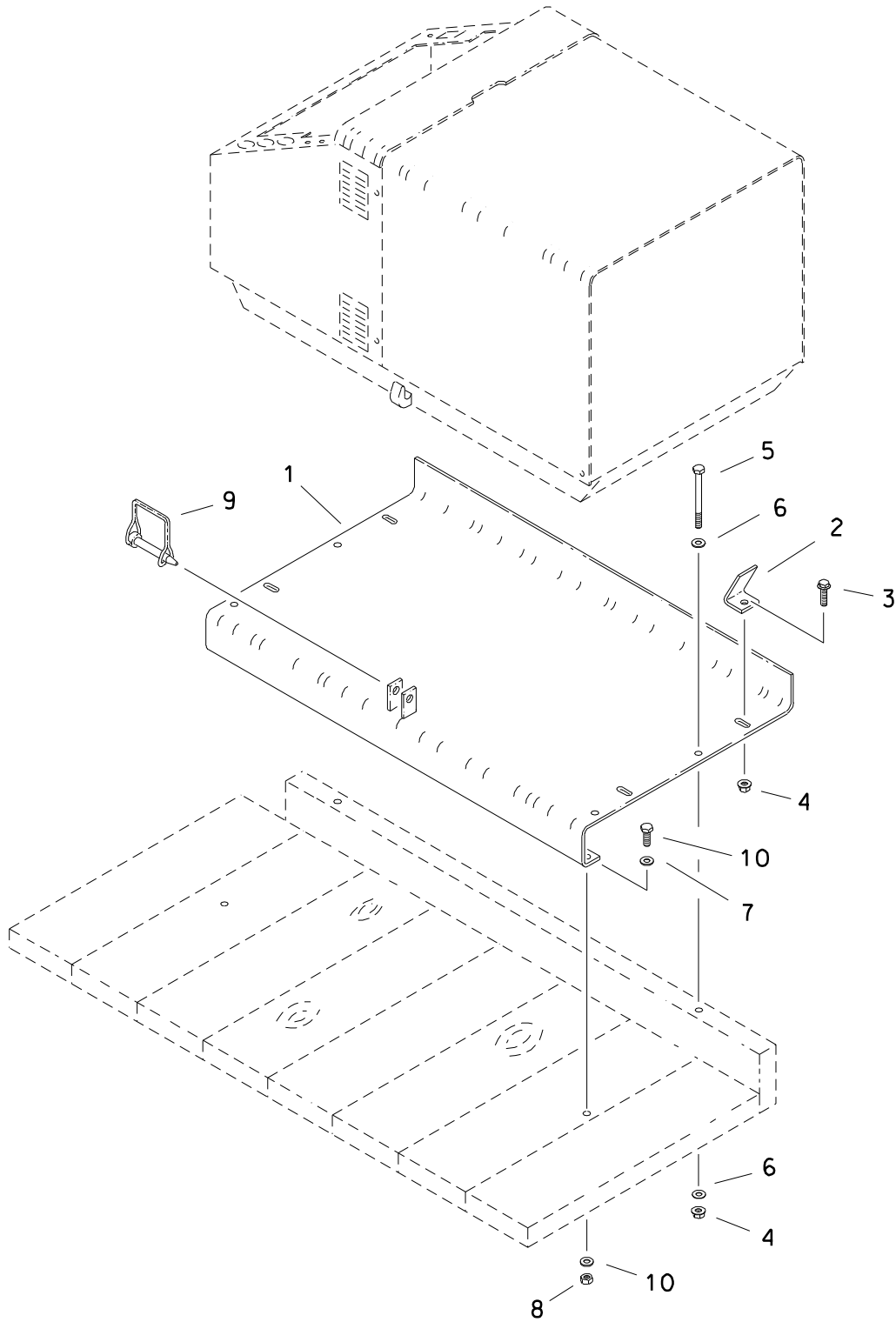

POWER PACK SUPPORT

REF NO.	PART NUMBER	QTY	DESCRIPTION	REMARKS
1.	351-644	1	SUPPORT	
2.	140-796	4	SLIDE STOP	
3.	105-827	4	FLG LK BOLT (3/8-NC X 1-1/4")	
4.	105-834	6	FLG LOCKNUT (3/8-NC)	
5.	105-808	2	BOLT (3/8-NC X 7")	
6.	105-118	4	WASHER (3/8")	
7.	105-067	2	BOLT (1/2-NC X 2-3/4")	
8.	105-021	2	NUT (1/2-NC)	
9.	110-032	2	SNAPPER PIN (5/16" X 2-1/2")	
10.	105-071	4	WASHER (1/2")	

FOOTNOTES

ROD RACK

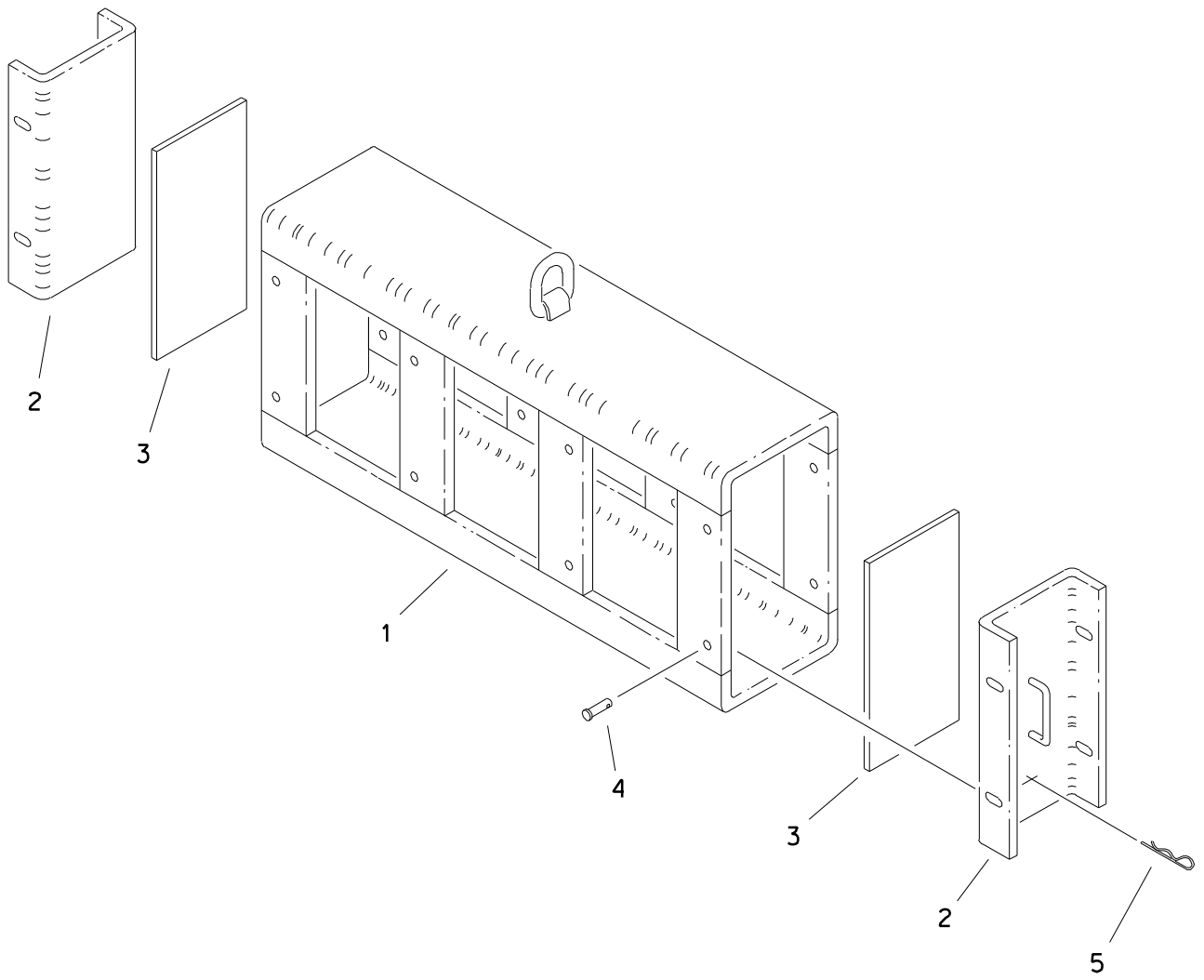

ROD RACK

REF NO.	PART NUMBER	QTY	DESCRIPTION	REMARKS
1.	326-182	1	ROD RACK	
2.	326-999	2	END PLATE	
3.	326-185	2	END PLATE (OLD STYLE)	SEE FOOTNOTE 1 AND 2
3.	116-345	2	PAD	
4.	110-306	8	CLEVIS PIN (0.375 X 1.125)	
5.	110-033	8	SPRING CLIP PIN (0.125 X 0.500)	

FOOTNOTES

- BOND ITEM END PLATE AND PAD WITH "PERMABOND 240" ADHESIVE OR EQUAL.
- OLD STYLE END PLATES (326-185) WITH RODS THAT HAVE NEW THREAD PROTECTORS, WILL REQUIRE KIT 190-566.
- ROD RACK ASSEMBLY 326-181 HOLDS 18 P80 RODS / 30 P40 RODS

HYDRAULICS

HYDRAULIC SCHEMATIC

P40 / P80

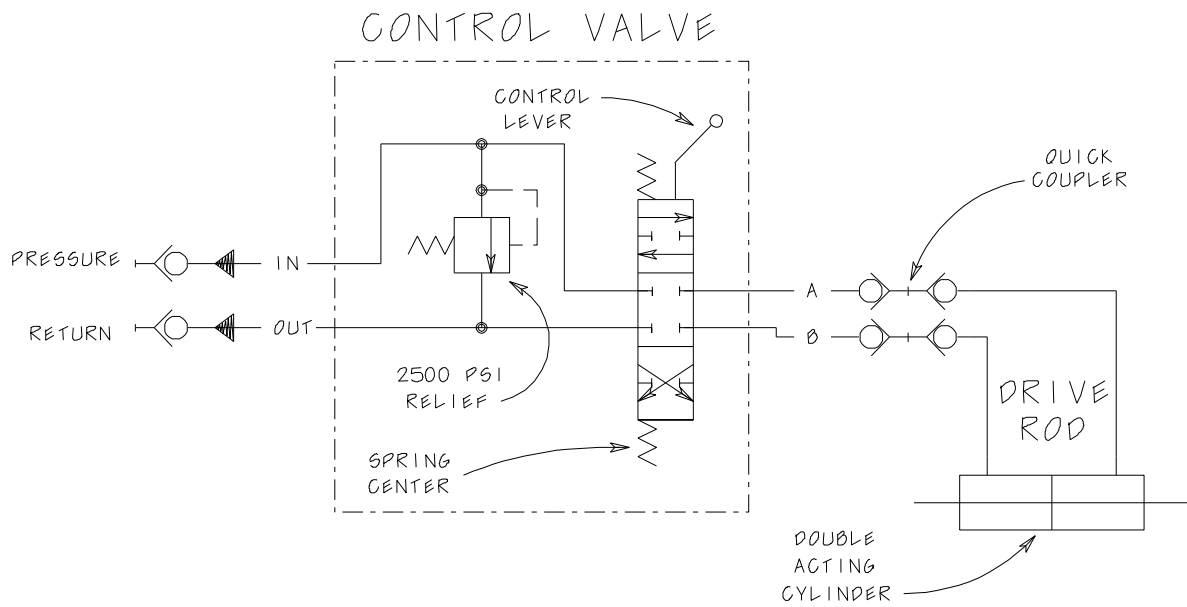

NOTE: MANIFOLD CONNECTIONS ON MACHINE HYDRAULIC SCHEMATIC.

HYDRAULIC SCHEMATIC

P40 / P80

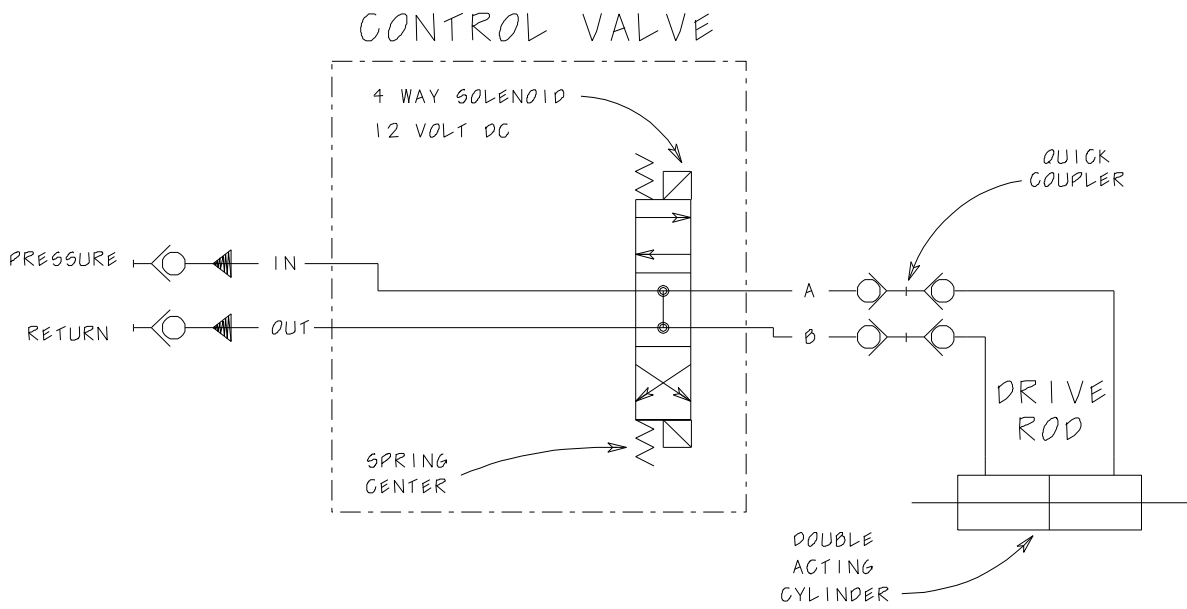

NOTE: MANIFOLD CONNECTIONS ON MACHINE HYDRAULIC SCHEMATIC.

DRIVE HYDRAULICS

P40 & P80 WITH SOLENOID CONTROL VALVE

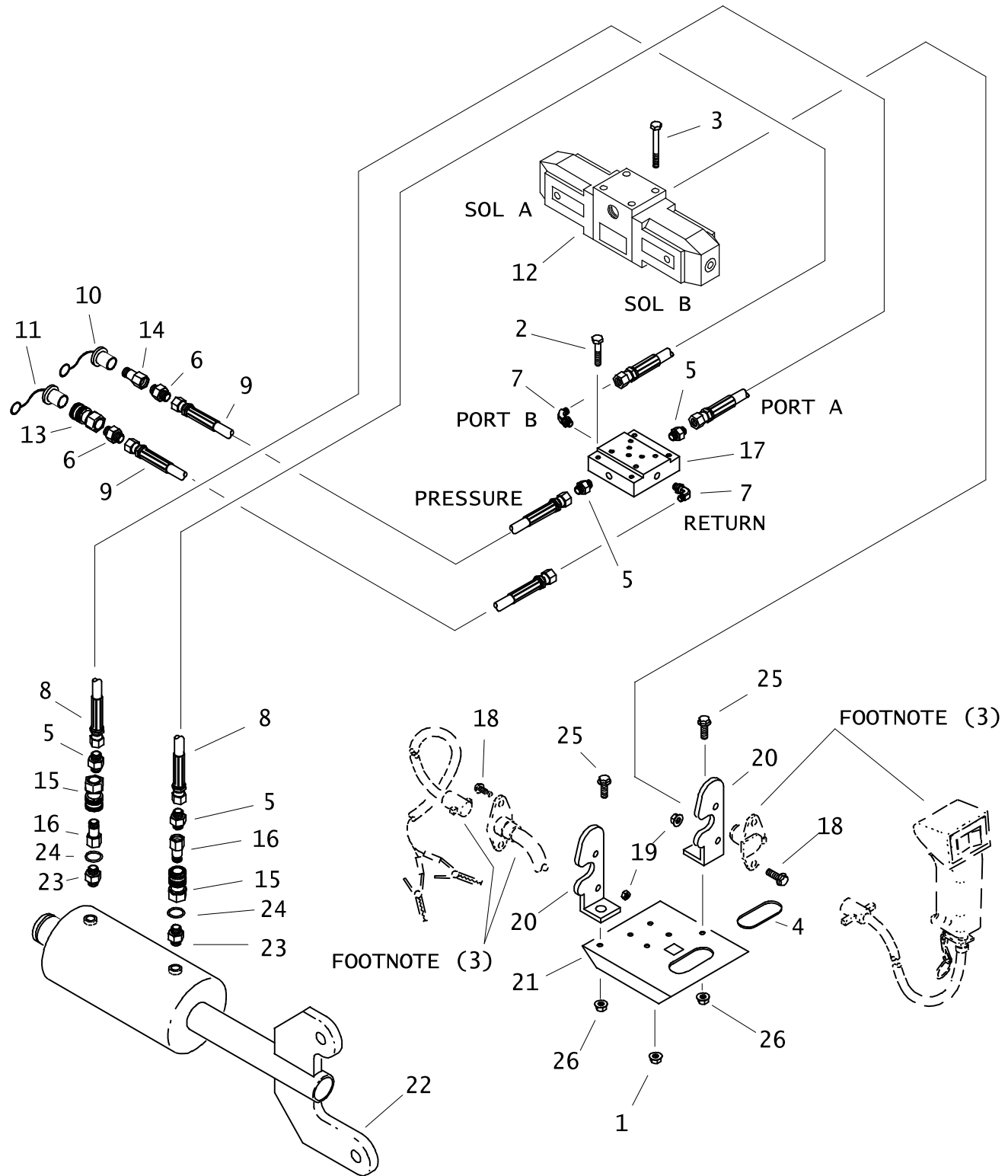

DRIVE HYDRAULICS P40 & P80 WITH SOLENOID CONTROL VALVE

REF NO.	PART NUMBER	QTY	DESCRIPTION	REMARKS
	100-714		SOLENOID CONTROL VALVE KIT	INCL. REF. NO.'S 1 THRU 26, SEE FOOTNOTE 1
1.	105-053	4	NUT	
2.	105-156	4	BOLT (3/8-NC X 1-1/2")	
3.	105-261	4	BOLT (1/4-NC X 1-1/2", GD 8)	
4.	115-686	AR	GROMMET EDGING	USE 16"
5.	154-233	4	CONNECTOR (08 O/08 S)	
	155-778		O-RING (014 D70, VITON)	
	155-706		O-RING (908 D90)	
6.	154-234	2	CONNECTOR (08 O/12 S)	
	155-778		O-RING (014 D70, VITON)	
	155-709		O-RING (912 D90)	
7.	154-235	2	CONNECTOR (08 O/08,90)	
	155-778		O-RING (014 D70, VITON)	
	155-706		O-RING (908 D90)	
8.	154-662	2	HOSE (98", 3000 PSI)	SEE FOOTNOTE 2
9.	154-663	2	HOSE (170", 3000 PSI)	SEE FOOTNOTE 2
10.	155-935	1	DUST CAP	
11.	155-936	1	DUST PLUG	
12.	158-583	1	SOLENOID CONTROL VALVE	
	217-737		SOLENOID REPAIR KIT	2 PER UNIT
	500-690		SEAL KIT	
13.	159-004	1	QUICK BODY	
14.	159-007	1	QUICK ADAPTER	
15.	159-029	2	QUICK BODY	
16.	159-030	2	QUICK ADAPTER	
17.	159-059	1	SUBPLATE	
18.	105-820	4	FLANGE LOCK BOLT (1/4-NC X 3/4")	
19.	105-832	4	FLANGE LOCKNUT (1/4-NC)	
20.	362-746	2	RECEPTACLE BRACKET	
21.	363-019	1	BRACKET	
22.	151-024	1	CYLINDER (5.0" X 2.25" X 9.0")	5" - P40
	151-025	1	CYLINDER (7.0" X 2.75" X 9.0")	SEE FOOTNOTE 4; ENDS WITH S/N CMWP80_90000223.
	150-3036	1	P80 CYLINDER ASSEMBLY	SEE FOOTNOTE 4; BEGINS WITH S/N CMWP80P90000225
23.	154-005	2	CONNECTOR (08 S)	
	155-706		O-RING (908 D90)	
24.	155-706	2	O-RING (908 D90)	
25.	501-325	2	FLANGE LOCK BOLT (5/16-NC X 5/8")	
26.	105-003	2	FLANGE LOCKNUT (5/16-NC)	

NOT SHOWN:

154-274	2	ADAPTER CONNECTOR (13/16-ORS M X 13/16-ORS M, STR)	SEE FOOTNOTE 2
155-778		ORS O-RING (-014)	

FOOTNOTES:

- REFER TO INSTALLATION DIAGRAM 050-190.
- TO PROVIDE GREATER HOSE LENGTH, ORDER SETS OF HOSE (REF. NO. 8 OR 9) AND CONNECTOR (08 O/08 S) LISTED UNDER NOT SHOWN.
- SEE PAGE ENTITLED "ELECTRICAL DIAGRAM, P40/P80, PRESENT PRODUCTION".
- 5X 106-012 (5/8-NC X 3") MOUNTING BOLTS REQ'D.

NOTE:

DRIVE HYDRAULICS

P40 / P80
EARLY STYLE

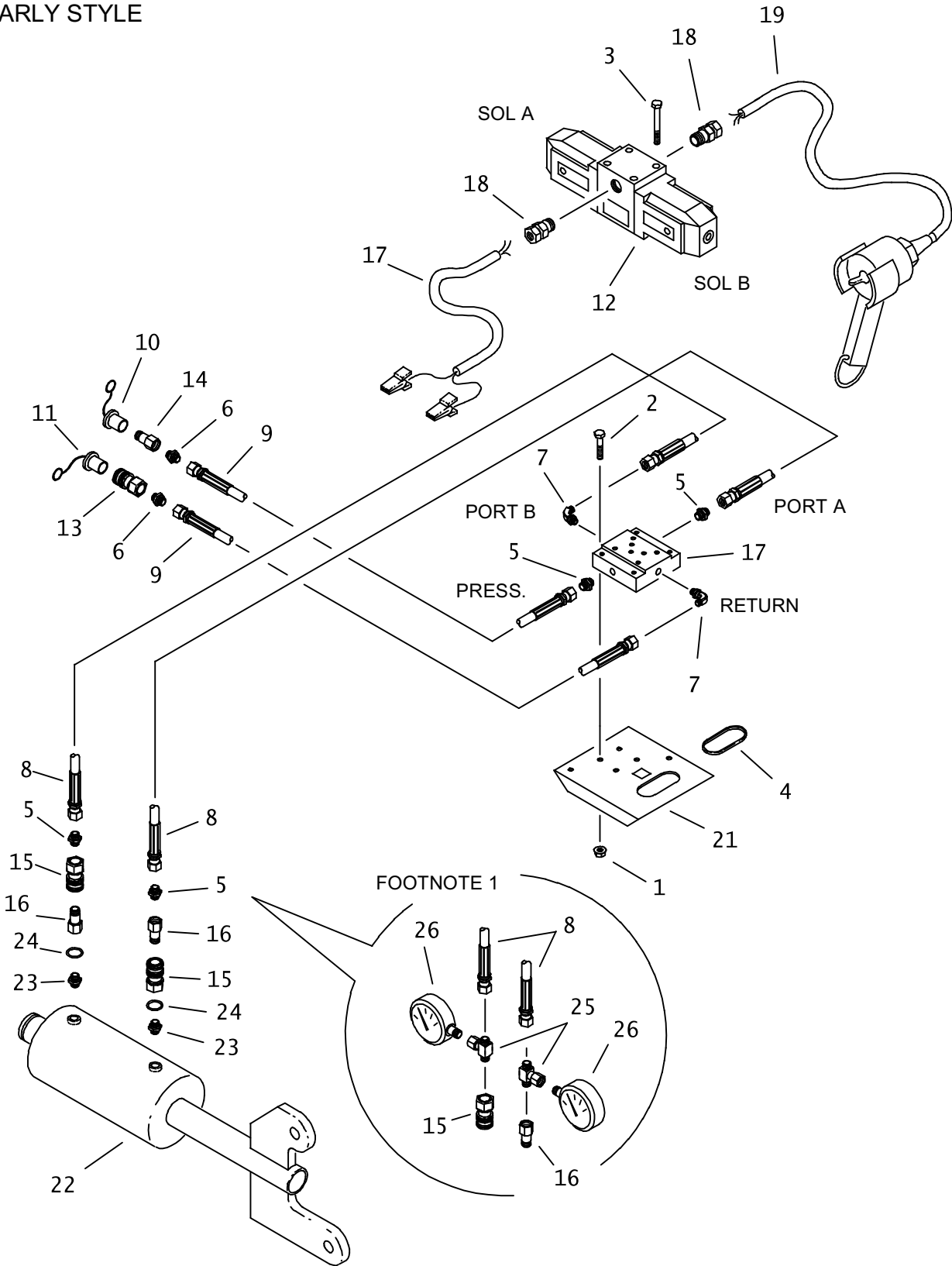

DRIVE HYDRAULICS**P40 / P80****EARLY STYLE**

REF NO.	PART NUMBER	QTY	DESCRIPTION	REMARKS
	100-714		SOLENOID CONTROL VALVE	INCL REF NO.'S 1 THRU 22. SEE FOOTNOTE 3
1.	105-053	4	NUT (3/8-NC)	
2.	105-156	4	BOLT (1/4-NC X 1-1/2")	
3.	105-261	4	BOLT (1/4-NC X 1-1/2", ALN HD)	
4.	115-686	AR	GROMMET EDGING	USE 16"
5.	154-233	4	CONNECTOR (08S-080)	
6.	154-234	2	CONNECTOR (12S-080)	
7.	154-235	2	CONNECTOR (080-08s 90)	
8.	154-662	2	HOSE (080-98"-3000)	SEE FOOTNOTE 2
9.	154-663	2	HOSE (080-170"-3000)	SEE FOOTNOTE 2
10.	155-935	1	DUST CAP	
11.	155-936	1	DUST PLUG	
12.	158-583	1	SOLENOID CONTROL VALVE	WITHOUT MANUAL OVERRIDE
	158-583	1	SOLENOID CONTROL VALVE	WITH MANUAL OVERRIDE
13.	159-004	1	QUICK BODY (1-1/16 SAE, JIC)	
14.	159-007	1	QUICK ADAPTER (1-1/16 SAE, JIC)	
15.	159-029	2	QUICK BODY (1/2 X 3/4-SAE)	
16.	159-030	2	QUICK ADAPTER (1/2 X 3/4-SAE)	
17.	159-059	1	SUBPLATE	
18.	215-691	4	CORD GRIP CONNECTOR	
19.	215-732	1	PENDENT CABLE	
	215-079		TOGGLE SWITCH	
20.	215-733	1	POWER CABLE	
	215-737		ALLIGATOR CLIPS (PAIR)	
21.	363-019	1	VALVE BRACKET	
22.	151-024	1	DRIVE ROD CYLINDER (5")	P40
	151-025	1	DRIVE ROD CYLINDER (7")	P80 - ENDS WITH S/N CMWP80_90000223.
	150-3036	1	P80 CYLINDER ASSEMBLY	SEE FOOTNOTE 4; BEGINS WITH S/N CMWP80P90000225.
23.	154-005	2	CONNECTOR (08S-08J)	
24.	155-706	2	O-RING (908 D90)	
25.	155-226	2	CONNECTOR (08S-080, 04NF)	SEE FOOTNOTE 1
26.	217-528	2	PRESSURE GAUGE (3000 PSI)	SEE FOOTNOTE 1

NOT SHOWN:
154-274 2 CONNECTOR (080-080)

FOOTNOTES:

1. THESE PARTS PROVIDE FOR PRESSURE GAUGE OPTION. SEE FOOTNOTE 3.
2. TO PROVIDE GREATER HOSE LENGTH, ORDER SETS OF HOSE (REF. NO.'S 8 OR 9) AND 154-274 CONNECTOR.
3. REFER TO INSTALLATION DIAGRAM 050-190.
4. 5X 106-012 (5/8-NC X 3") MOUNTING BOLTS REQD.

NOTE:

REFER TO O-RING CHART IN THE MISCELLANEOUS SECTION FOR REPLACEMENT OF SAE AND ORS CONNECTOR O-RINGS

DRIVE HYDRAULICS

P40 / P80

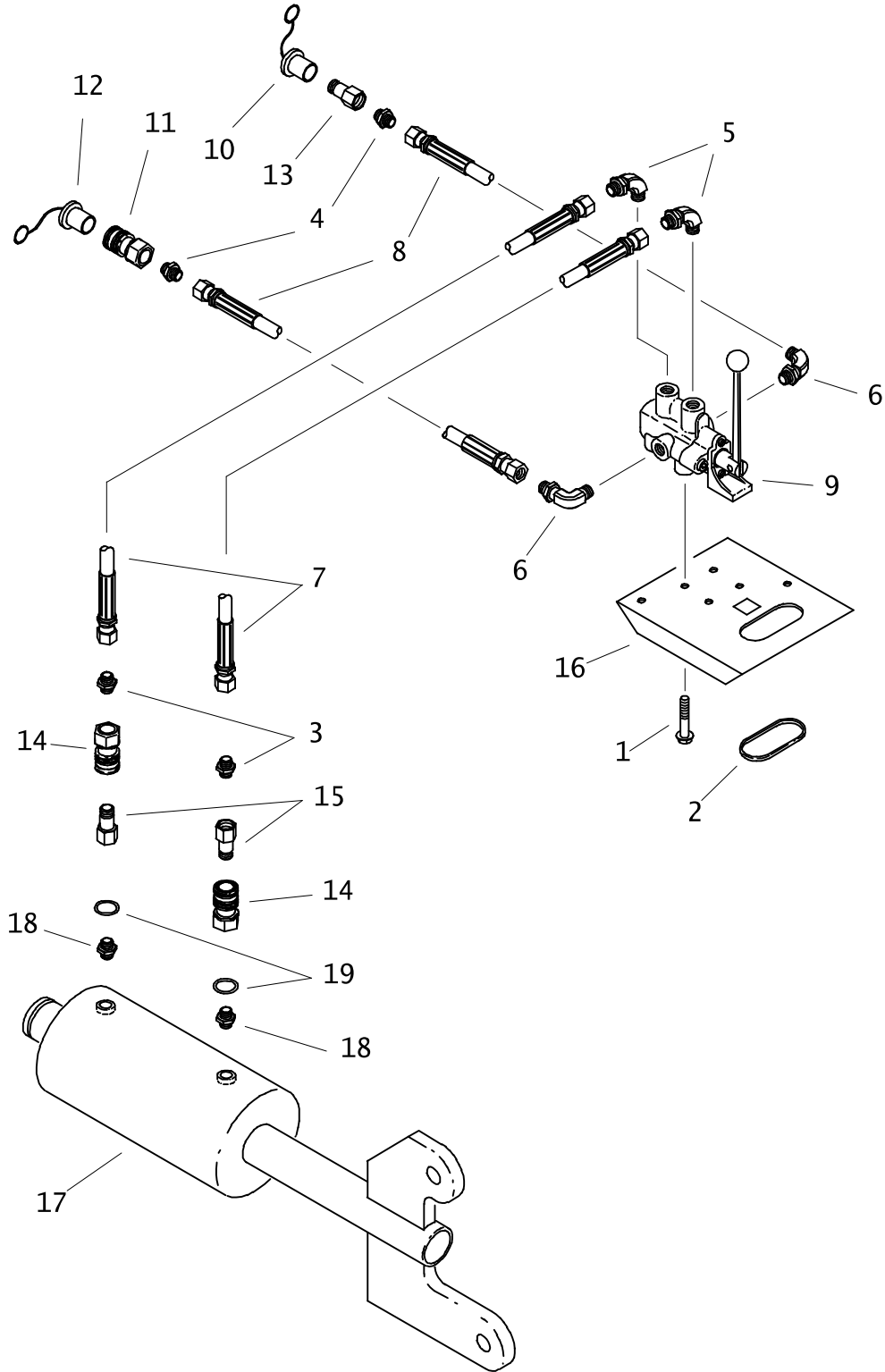

DRIVE HYDRAULICS

P40 / P80

REF NO.	PART NUMBER	QTY	DESCRIPTION	REMARKS
	100-702		CONTROL VALVE KIT	INCL REF NO.'S 1 THRU 16. SEE FOOTNOTE 1
1.	501-153	4	FLG LOCK BOLT (3/8-NC X 5/8")	
	105-181	4	BOLT (3/8-NC X 1/2")	
2.	115-686	AR	BULK EDGE (5/32", SOLD PER 1")	USE 16"
3.	154-233	2	CONNECTOR (08S-080)	
4.	154-234	2	CONNECTOR (12S-080)	
5.	154-235	2	CONNECTOR (080-08S 90)	
6.	154-236	2	CONNECTOR (12S-080 90)	
7.	154-662	2	HOSE (080-98"-3000)	SEE FOOTNOTE 2
8.	154-663	2	HOSE (080-170"-3000)	SEE FOOTNOTE 2
9.	155-621	1	HYDRAULIC CONTROL VALVE	
10.	155-935	1	DUST CAP	
11.	155-936	1	DUST PLUG	
12.	159-004	1	QUICK BODY (1-1/16 SAE, JIC)	
13.	159-007	1	QUICK ADAPTER (1-1/16 SAE, JIC)	
14.	159-029	2	QUICK BODY (1/2 X 3/4-SAE)	
15.	159-030	2	QUICK ADAPTER (1/2 X 3/4-SAE)	
16.	363-019	1	VALVE BRACKET	
17.	151-024	1	CYLINDER (5.0" X 2.250" X 9.000")	P40
	151-025	1	CYLINDER (7.0" X 2.750" X 9.000")	P80-ENDS WITH S/N CMWP80_90000223.
	150-3036	1	P80 CYLINDER ASSEMBLY	SEE FOOTNOTE 3; BEGINS WITH S/N CMWP80P90000225.
18.	154-005	2	CONNECTOR (08S-08J)	
19.	155-706	2	O-RING (908 D90)	

NOT SHOWN:

154-274	2	CONNECTOR (080-080)	SEE FOOTNOTE 2
---------	---	---------------------	----------------

FOOTNOTES:

- 1 - REFER TO INSTALLATION DIAGRAM 050-144.
- 2 - TO PROVIDE GREATER HOSE LENGTH, ORDER SETS OF HOSE (REF NO.'S 7 OR 8) AND 154-274 CONNECTOR.
- 3 - 5X 106-012 (5/8-NC X 3") MOUNTING BOLTS REQ'D.

NOTE:

REFER TO O-RING CHART IN THE MISCELLANEOUS SECTION FOR REPLACEMENT OF SAE AND ORS CONNECTOR O-RINGS.

HYDRAULIC CONTROL VALVE SINGLE SPOOL

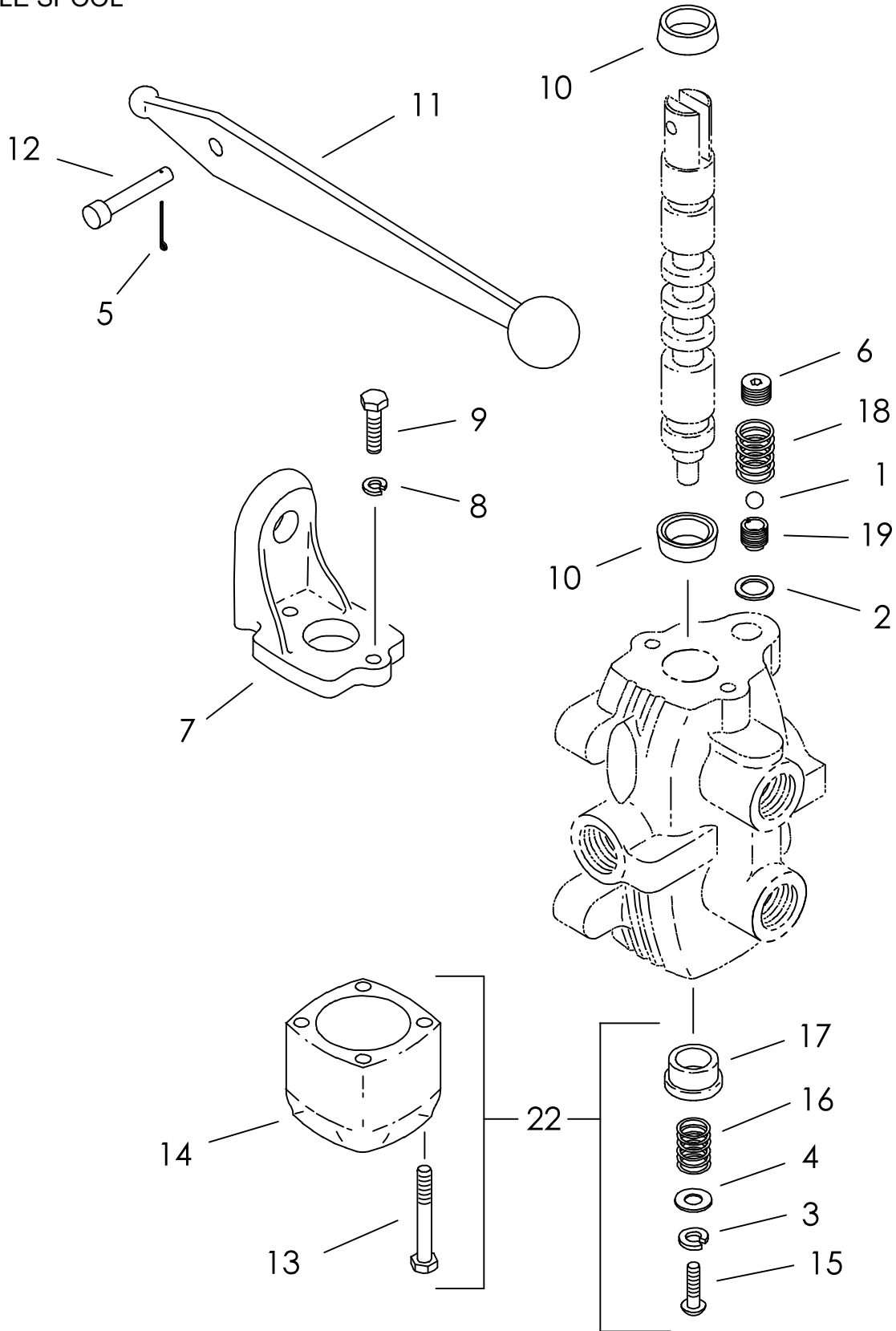

HYDRAULIC CONTROL VALVE SINGLE SPOOL

REF NO.	PART NUMBER	QTY	DESCRIPTION	REMARKS
	155-621		HYDRAULIC CONTROL VALVE	INCL REF NO.'S 1 THRU 20. SEE FOOTNOTE 2
1.	500-186	1	RELIEF BALL	
2.	500-185	1	O-RING (110, D70)	
3.	105-079	1	LOCK WASHER (1/4)	
4.	105-226	1	WASHER (5/16)	
5.	105-512	1	COTTER PIN (3/32 X 3/4")	
6.	115-178	1	PLUG (06N, SQ FM HD)	
7.	500-054	1	LEVER BRACKET	
8.	500-055	2	LOCK WASHER (1/4")	
9.	500-056	2	BOLT (1/4-NC X 5/8", SLOT HD)	
10.	500-057	2	CUP SEAL	
11.	500-058	1	CONTROL VALVE LEVER	
12.	500-059	1	LEVER PIN	
13.	500-060	4	BOLT	SEE FOOTNOTE 1
14.	500-061	1	DETENT BONNET	SEE FOOTNOTE 1
15.	501-179	1	SCREW (1/4 X 1/2)	
16.	500-065	1	COMPRESSION SPRING	SEE FOOTNOTE 1
17.	500-066	1	SPOOL COLLER	SEE FOOTNOTE 1
18.	500-182	1	COMPRESSION SPRING	
19.	500-184	1	RELIEF SEAT	
20.	500-374		NEUTRAL RETURN CONVERSION KIT	INCL REF NO.'S 3, 4 AND 13 THRU 17

NOT SHOWN:

FOOTNOTES:

1 - IF REPLACEMENT OF THESE PARTS IS NECESSARY, ORDER RETURN KIT (REF NO. 20) AND REFER TO INSTALLATION DIAGRAM 050-088.

2 - REFER TO INSTALLATION DIAGRAM 052-141 FOR ADJUSTMENT OF PRESSURE RELIEF.

NOTE:

DRIVE ROD CYLINDER P40

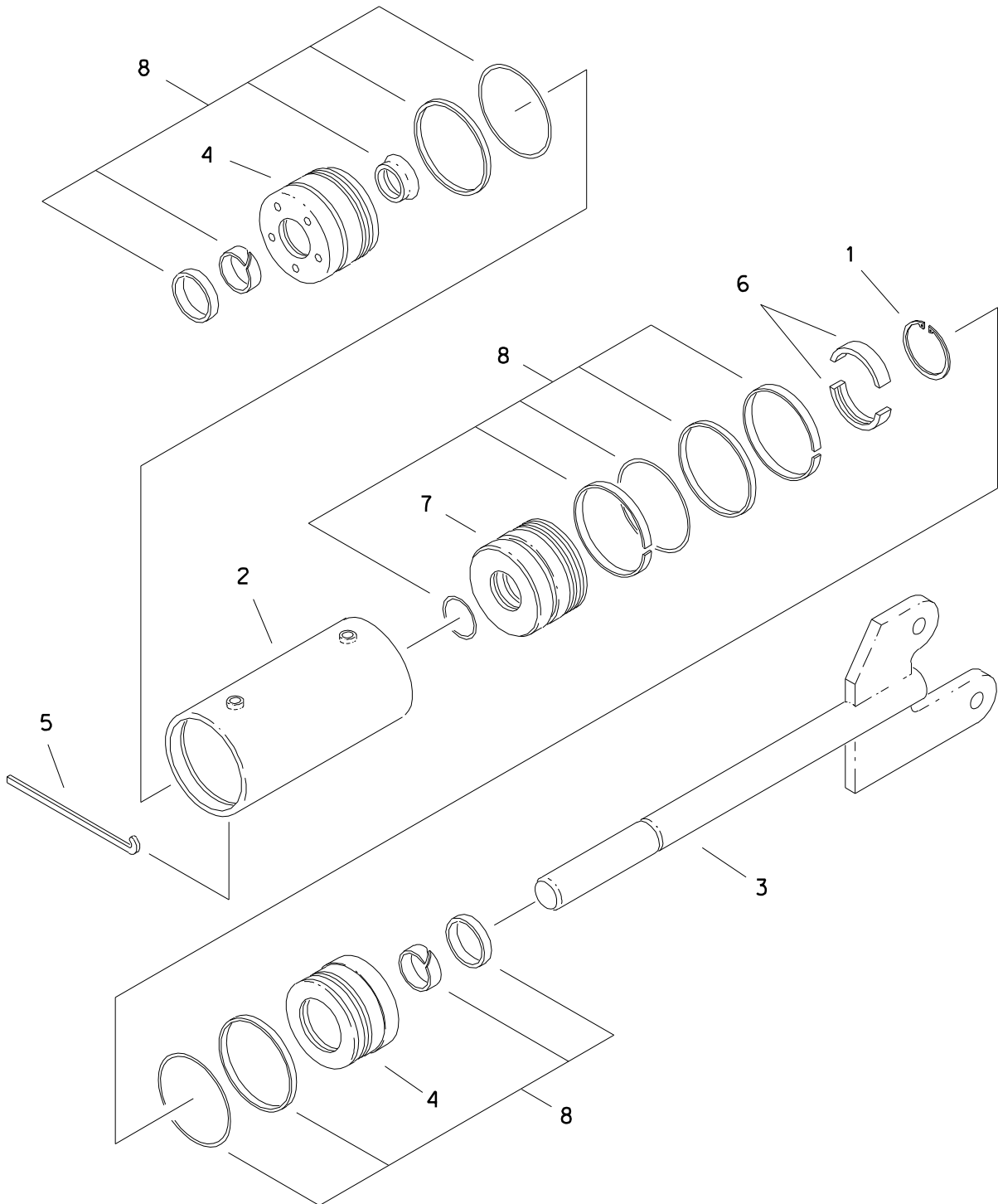

DRIVE ROD CYLINDER P40

REF NO.	PART NUMBER	QTY	DESCRIPTION	REMARKS
	151-024		DRIVE ROD CYLINDER	INCL REF NO.'S 1 THRU 8
1.	115-533	1	INTERNAL SNAP RING	
2.	150-280	1	CYLINDER BARREL	
3.	150-412	1	CYLINDER ROD	
4.	150-791	2	CYLINDER HEAD (5" OD)	
5.	150-968	2	LOCK RING	
6.	150-969	1	RETAINER RING	
7.	150-970	1	PISTON (5" OD)	
8.	190-163	1	SEAL REPAIR KIT	SEE FOOTNOTE 1

NOT SHOWN:

	259-133		PISTON RING COMPRESSOR	
	259-134		PISTON RING GUIDE	
	259-135		HEAD SPANNER	

FOOTNOTES

1 - REFER TO INSTALLATION DIAGRAM 050-114.

DRIVE ROD CYLINDER

P80
BEGINS WITH S/N CMWP80P90000225

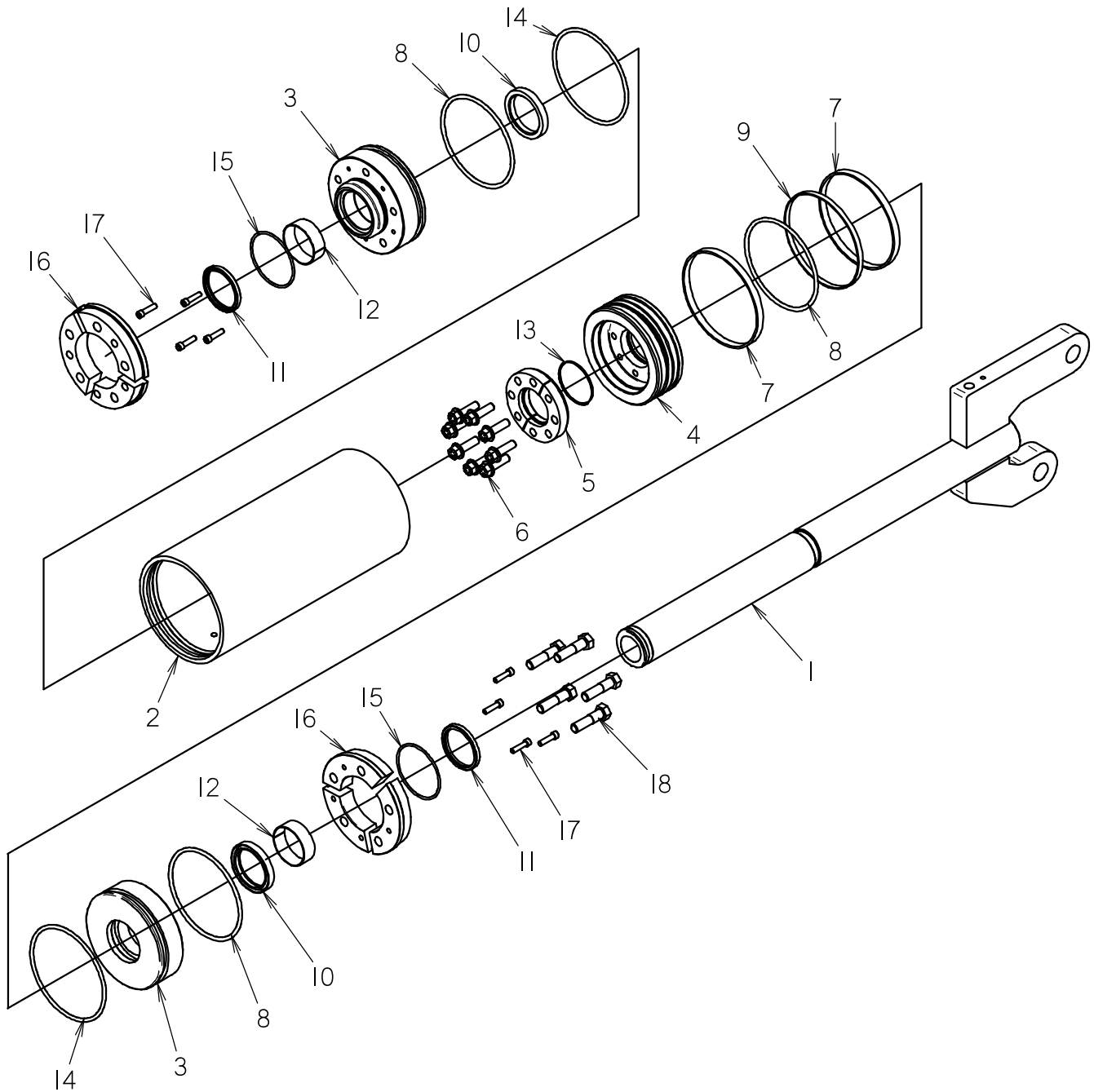

**DRIVE ROD CYLINDER
P80
BEGINS WITH S/N CMWP80P90000225**

REF NO.	PART NUMBER	QTY	DESCRIPTION	REMARKS
	150-3060	-	P80 CYLINDER ASSEMBLY	INCLUDES REF #'S 1 THRU 18
1	150-413	1	ROD ASSEMBLY	
2	150-3037	1	BARREL ASSEMBLY	
3	150-3039	2	CYLINDER HEAD	
4	149-305	1	PISTON	
5	149-306	1	RETAINER RING	
6	106-096	8	FLG BOLT (1/2-NC X 1-3/4",GD8)	
7	125-766	2	WEAR RING	
8	157-013	3	O-RING (438 D90)	
9	157-529	1	BACKUP RING (438 D90)	
10	157-531	2	U-SEAL SEAL	
11	157-530	2	WIPER SEAL (2.750")	
12	125-767	2	WEAR RING	
13	157-015	1	O-RING (232 D70)	
14	157-014	2	BACKUP RING (439 D90)	
15	155-764	2	O-RING (240 D70)	
16	150-3040	2	3-PIECE HEAD RETAINER	
17	106-125	8	BOLT (5/16-NC X 1 1/4", SOC)	USE LOCTITE 277 OR EQUIVALENT.
18	105-437	5	BOLT (5/8-NC X 2-1/2" GR. 5)	USE LOCTITE 277 OR EQUIVALENT.

NOT SHOWN:

259-136 PISTON RING COMPRESSOR
259-137 PISTON RING GUIDE

FOOTNOTES:

1. REPLACEMENT FOR 151-025. 5X 106-012 (5/8-NC X 3") MOUNTING BOLTS REQ'D.

NOTE:

DRIVE ROD CYLINDER
P80
ENDS WITH S/N CMWP80_90000223

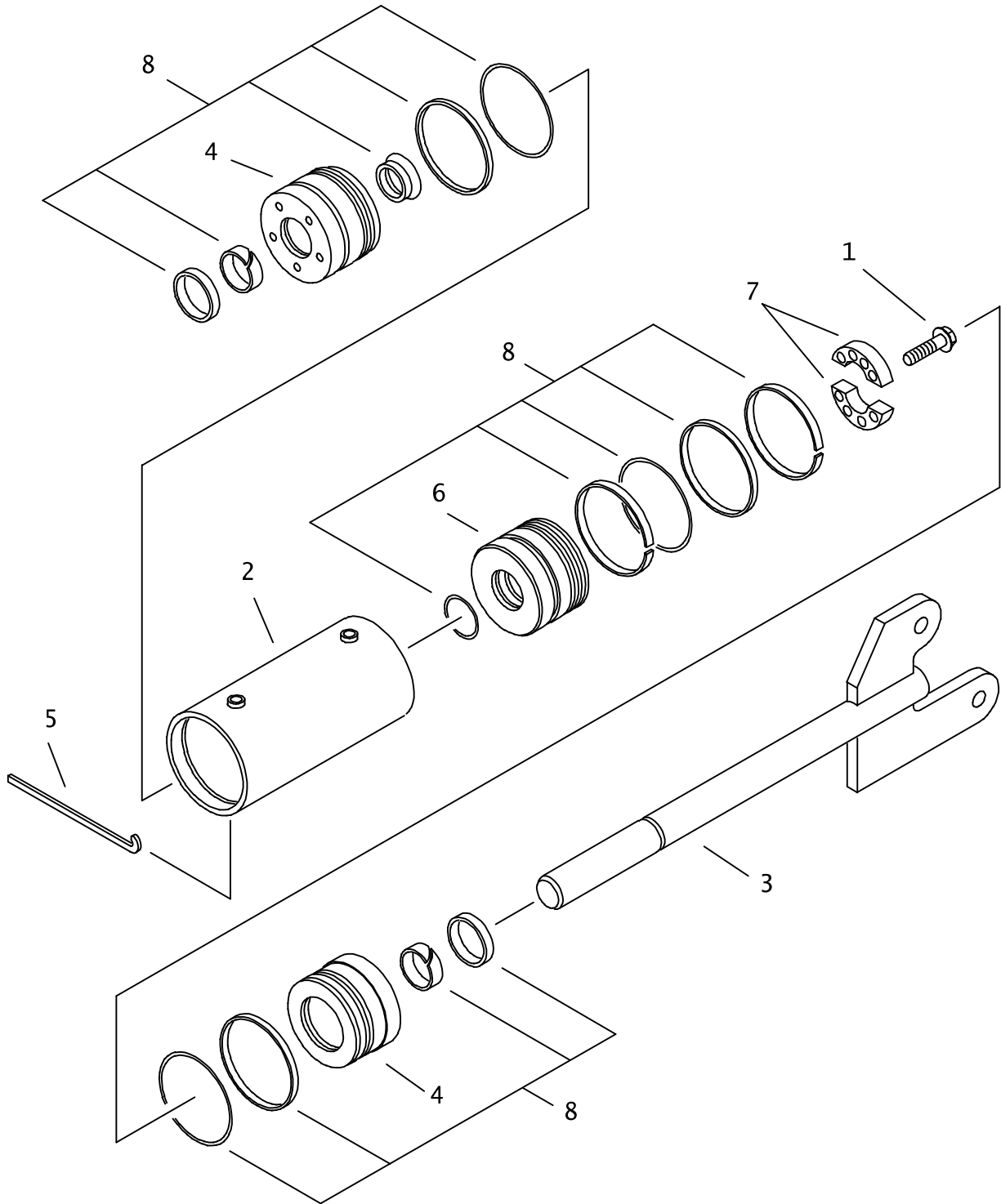

DRIVE ROD CYLINDER
P80
ENDS WITH S/N CMWP80_90000223

REF PART NO.	NUMBER	QTY	DESCRIPTION	REMARKS
	151-025		CYL (7.0" X 2.750" X 9.000")	SEE FOOTNOTES 2 & 3.
1.	115-534	1	INTERNAL SNAP RING	
	106-096	8	FLG BOLT (1/2-NC X 1-3/4",GD8)	
2.	150-281	1	CYLINDER B RREL	
3.	150-413	1	CYLINDER ROD	
4.	150-788	2	CYLINDER HEAD	
5.	150-972	2	LOCK RING	
6.	150-973	1	PISTON	
	149-305	1	PISTON	
7.	150-974	1	RETAINER RING	
	149-306	1	RETAINER RING	
8.	190-164	1	SEAL REPAIR KIT	SEE FOOTNOTE 1

NOT SHOWN:

259-136 PISTON RING COMPRESSOR
 259-137 PISTON RING GUIDE
 259-135 HEAD SPANNER

FOOTNOTES:

1 - REFER TO INSTALLATION DIAGRAM 050-115.
 2 - INCLUDES REFERENCE NUMBERS 1 THRU 8.
 3 - SUPERSEDED BY 150-3036; BEGINS WITH S/N CMWP80P90000225.

NOTE:

SOLENOID CONTROL VALVE

P40 / P80
EARLY STYLE

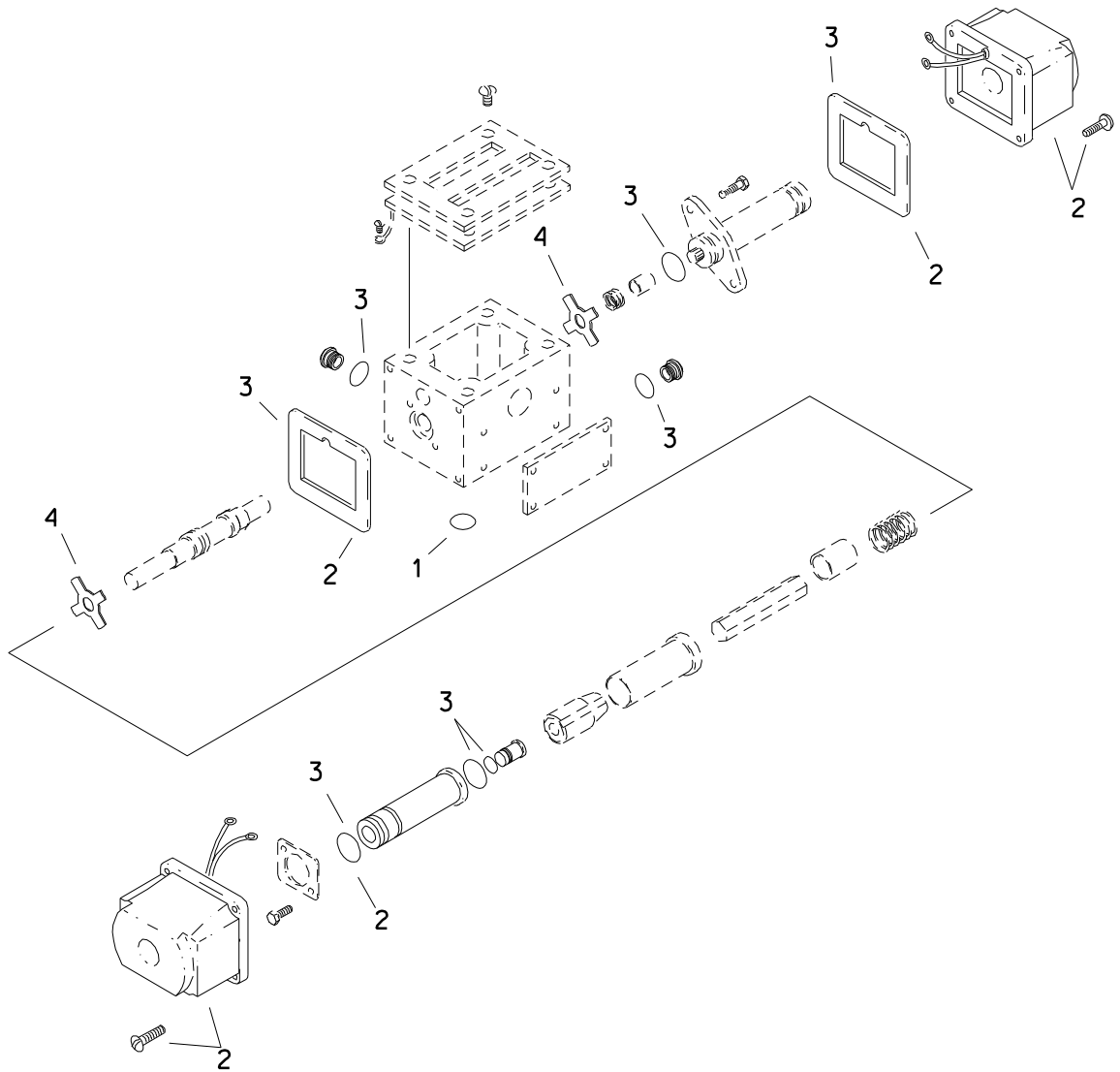

SOLENOID CONTROL VALVE
P40 / P80
EARLY STYLE

REF NO.	PART NUMBER	QTY	DESCRIPTION	REMARKS
	158-504		SOLENOID CONTROL VALVE	INCL REF NO.'S 1 THRU 3
1.	155-778	5	O-RING	
2.	500-370	2	COIL REPAIR KIT	INCL REF NO. 1
3.	500-495	1	SEAL REPAIR KIT	INCL REF NO. 1
4.	500-760	2	KNOB	

FOOTNOTES

ELECTRICAL

GRID SYSTEM HARDWARE

ELECTRICAL STRIKE INDICATOR

PRESENT PRODUCTION

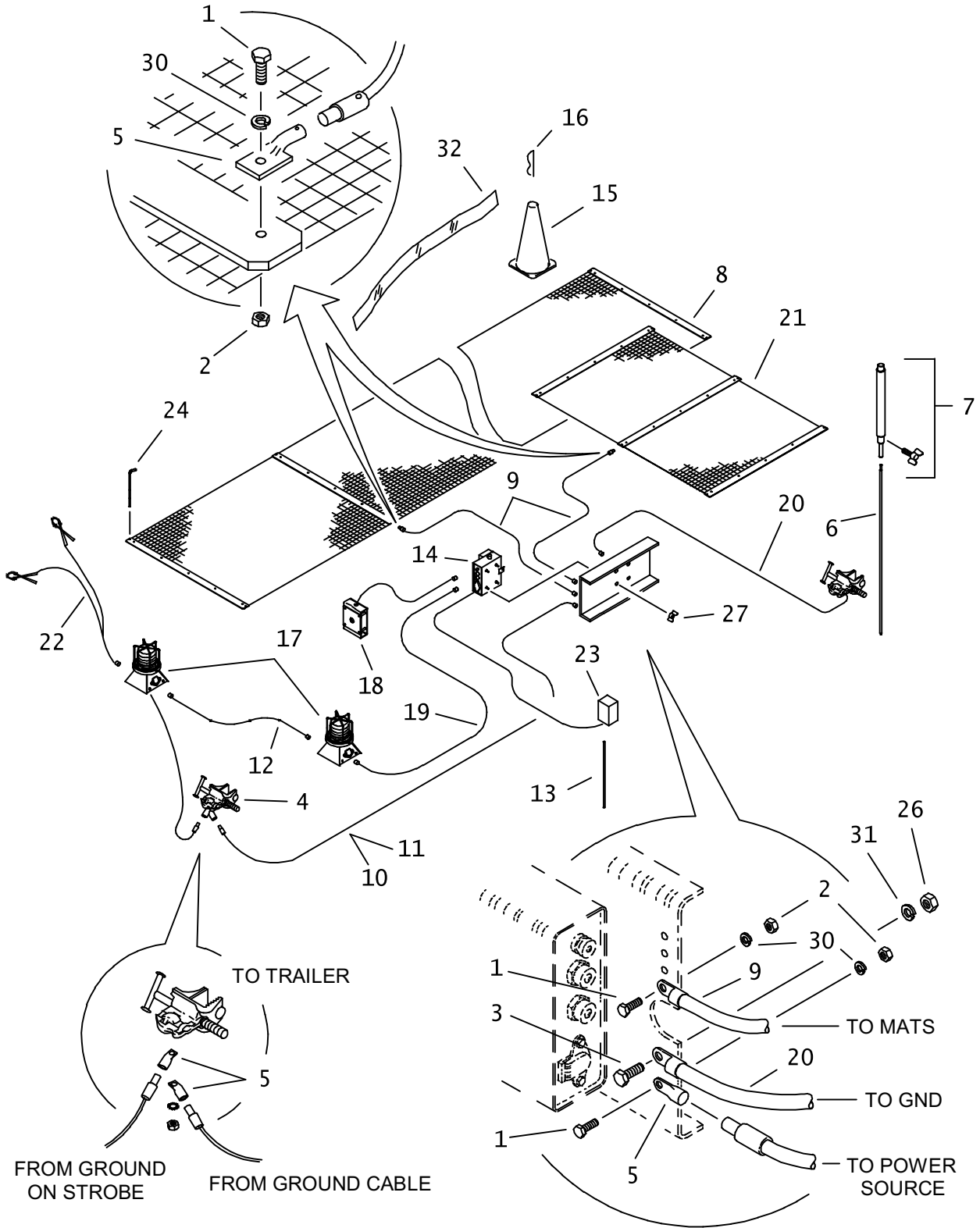

GRID SYSTEM HARDWARE

ELECTRICAL STRIKE INDICATOR
PRESENT PRODUCTION

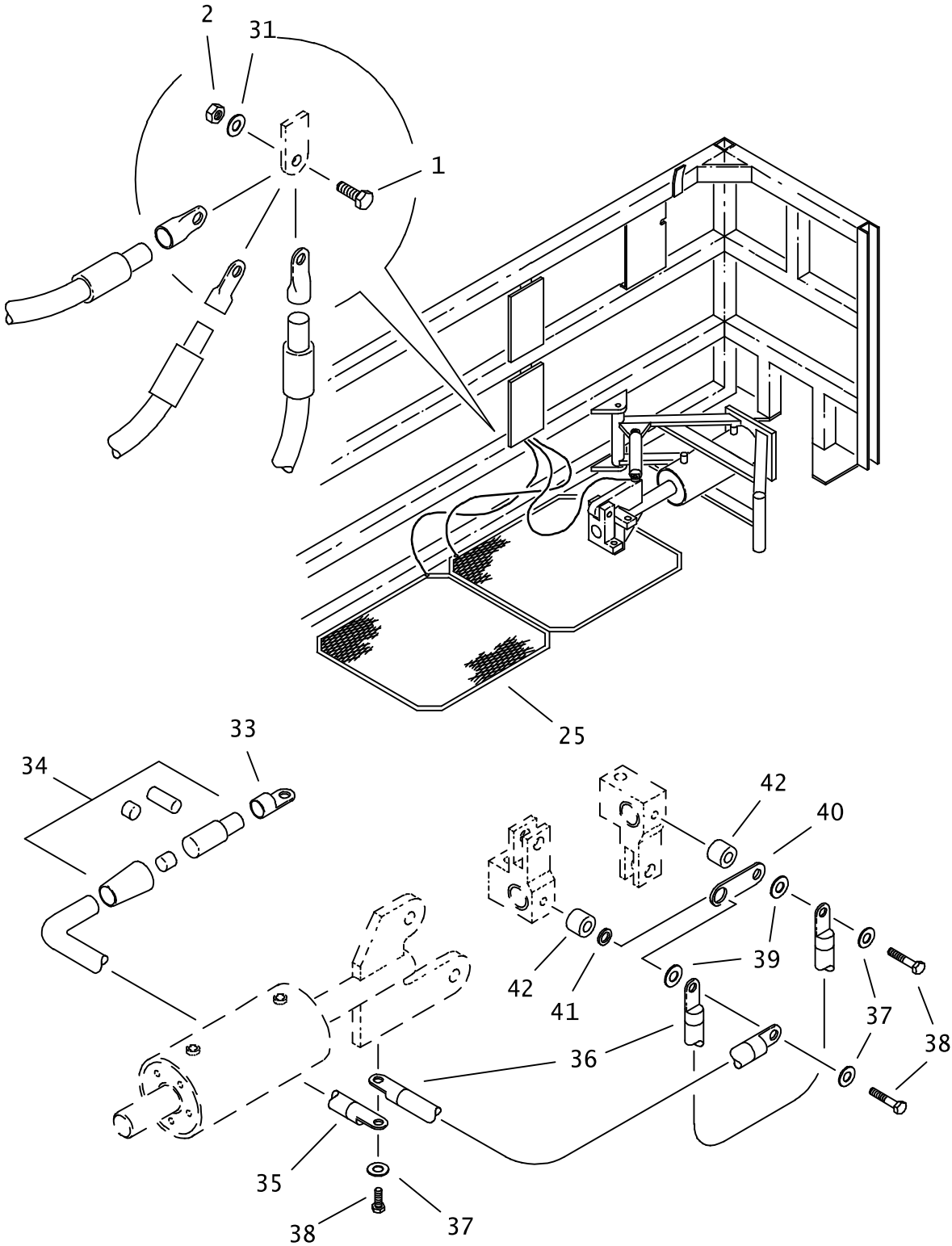

GRID SYSTEM HARDWARE

ELECTRICAL STRIKE INDICATOR

PRESENT PRODUCTION

REF NO.	PART NUMBER	QTY	DESCRIPTION	REMARKS
	100-741		ELECTRICAL STRIKE INDICATOR ADAPTION KIT	INCL REF NO.'S 1 THRU 32
1.	106-217	21	BOLT (1/4-NC X 1", SIL BRZ)	
2.	106-455	21	NUT (1/4-NC, SIL BRZ)	
3.	106-462	1	BOLT (3/8-NC X 1-1/4", SIL BRZ)	
4.	215-769	1	GROUND CLAMP	W/T-HANDLE CLAMP
5.	215-771	11	GROUNDING RECEPTACLE	
6.	215-775	1	GROUNDING ROD (72" LG)	
7.	215-776	1	SLIDE DRIVER	
	106-053		WING BOLT	
8.	215-777	2	GRID (20')	
9.	215-790	4	GROUND CABLE (20')	
10.	215-791	1	GROUND CABLE (50')	
11.	215-793	1	GROUND CABLE (200')	
12.	215-795	1	UMBILICAL CABLE (50')	
13.	215-799	1	VOLTAGE STAKE (23.5")	
14.	216-011	1	STRIKE INDICATOR BOX	
15.	259-210	8	TRAFFIC CONE	OBSOLETE
16.	259-234	8	BARRIER TAPE CLIP	OBSOLETE
17.	354-168	2	STROBE LIGHT PARTS ASSEMBLY	
	217-270	1	BULB (12V DC)	FOOTNOTE 1
	217-311	1	BULB (12V DC)	FOOTNOTE 2
	121-055	1	LENS (AMBER)	FOOTNOTE 3
18.	354-208	1	COIL BRACKET	
19.	215-826	1	UMBILICAL CABLE (25')	
20.	215-813	1	GROUND CABLE (25')	
21.	215-824	2	GRID (6')	
22.	215-825	1	POWER WIRE HARNESS	
23.	216-012	1	GROUND VOLTAGE LIMITER	
24.	183-658	12	MAT STAKE (15")	
25.	354-216	2	GRID (3')	
26.	106-454	1	NUT (3/8-NC, SIL BRZ)	
27.	195-339	2	WING NUT (1/4-NC)	
28.	215-828	1	GROUND CABLE (6', M TO M)	
29.	215-827	2	GROUND CABLE (6', M TO EYE)	
30.	106-221	21	LOCK WASHER (1/4", SIL BRZ)	
31.	106-220	1	LOCK WASHER (3/8", SIL BRZ)	YELLOW
32.	260-223	1	BARRIER TAPE ROLL (3" X 1000')	OBSOLETE
33.	215-771	1	GROUND RECEPTACLE	
34.	215-770	1	GROUND PLUG	
35.	215-899	1	CABLE (6GA X 4' M-EYE)	
36.	215-894	2	CABLE (6GA X 8.5" W/.375 EYE)	
37.	106-220	3	WASHER (3/8", SIL BRZ)	
38.	106-216	3	BOLT (3/8-NC X 1", SIL BRZ)	
39.	105-069	2	WASHER (3/8")	
40.	354-223	1	JAW CONNECTOR STRAP	
41.	116-443	1	RUBBER WASHER	
42.	184-187	2	BUSHING	

FOOTNOTES:

1. REPLACEMENT BULB FOR STROBE LIGHT 217-041
2. REPLACEMENT BULB FOR STROBE LIGHT 217-310.
3. REPLACEMENT LENS FOR STROBE LIGHT 217-310

NOTE:

STROBE LIGHT

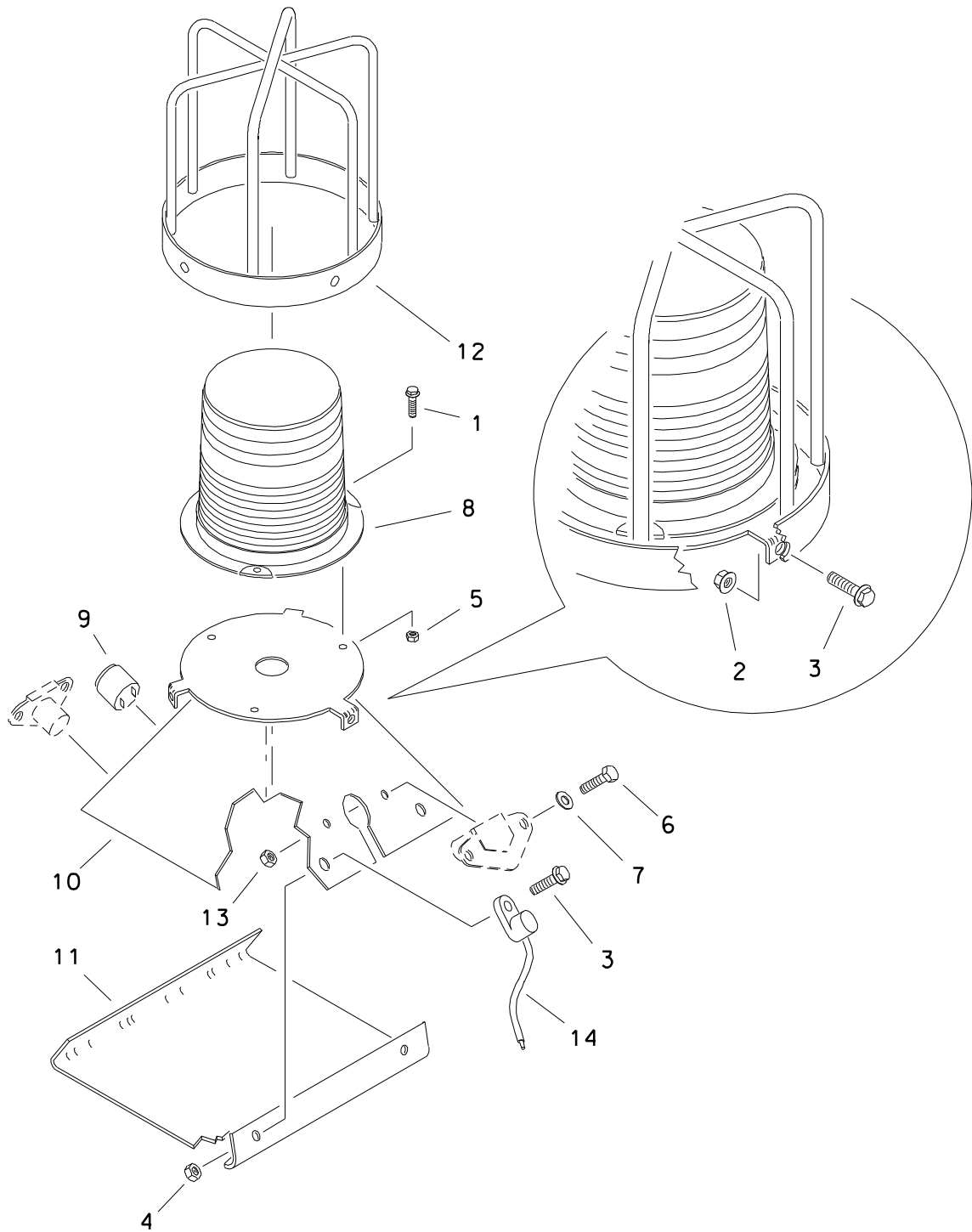

STROBE LIGHT

REF NO.	PART NUMBER	QTY	DESCRIPTION	REMARKS
	354-168		STROBE LIGHT	INCL REF NO.'S 1 THRU 14
1.	105-185	3	BOLT (10-24 X 1/2", RD SLT)	
2.	105-832	3	FLANGE LOCKNUT (1/4-NC)	
3.	105-836	7	FLG LOCK BOLT (1/4-NC X 1/2")	
4.	106-015	4	NUTSERT (1/4-NC)	
5.	106-048	3	LOCKNUT (10-24)	
6.	106-217	4	BOLT (1/4-NC X 1")	
7.	106-221	4	LOCK WASHER (1/4")	
8.	217-041	1	STROBE LIGHT	
	217-720		STROBE LAMP BULB	
	217-310	1	STROBE LIGHT (12V DC)	
	217-311	1	BULB (12V DC)	
	121-055	1	LENS (AMBER)	
9.	306-603	1	ALARM	
10.	354-187	1	LIGHT BASE	
11.	354-193	1	LIGHT BASE COVER	
12.	362-620	1	LIGHT COVER	
13.	106-455	4	NUT (1/4-NC, SIL BRZ)	
14.	215-827	1	GROUND CABLE (6 GA X 6')	

FOOTNOTES

CURRENT TRANSFORMER

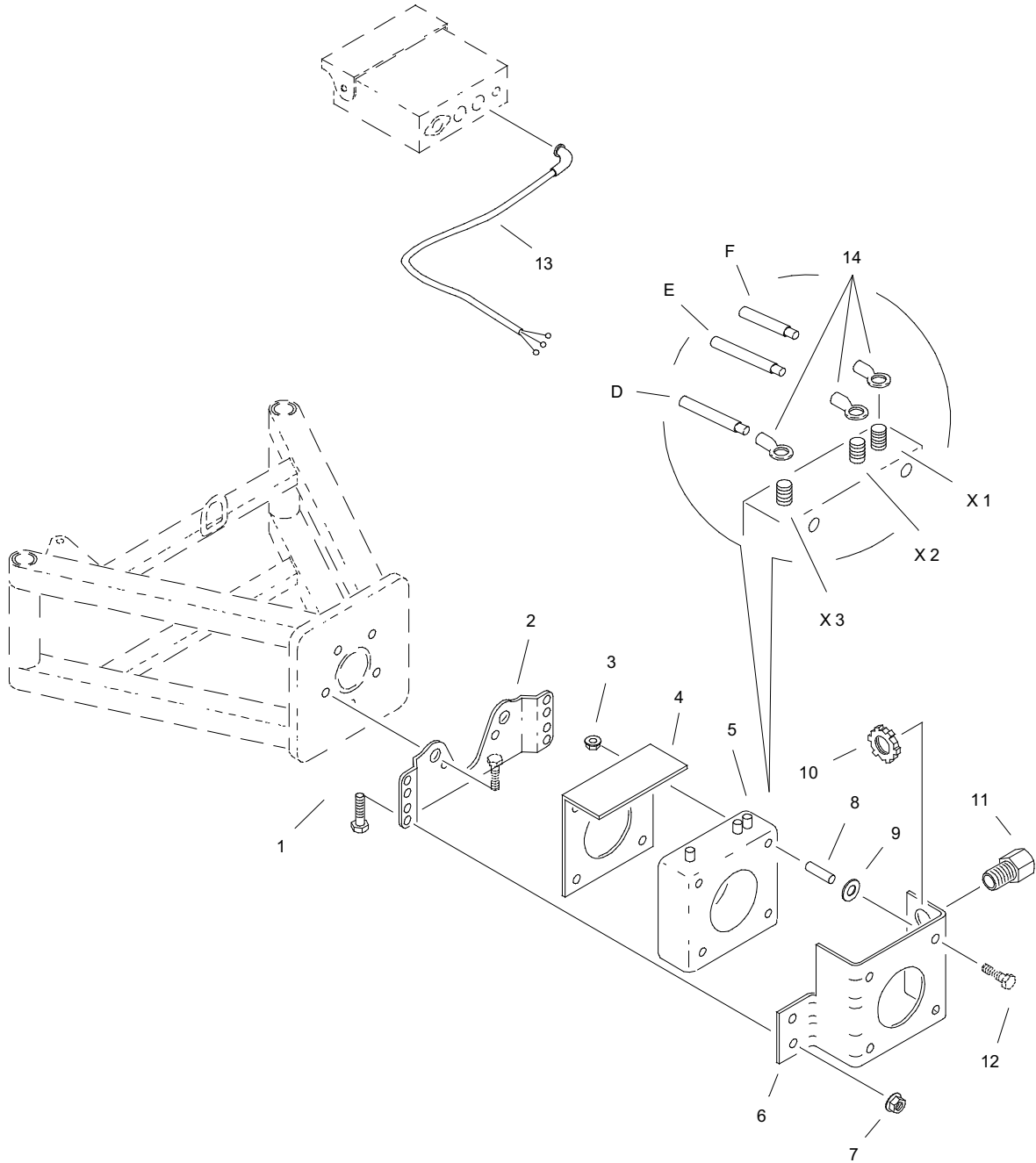

CURRENT TRANSFORMER

REF NO.	PART NUMBER	QTY	DESCRIPTION	REMARKS
	354-238		CURRENT TRANSFORMER ASSEMBLY	INCL REF NO.'S 1-14
1.	105-826	4	SCREW (3/8-NC X 1")	
2.	362-790	1	BRACKET	SEE FOOTNOTE 2
3.	105-832	4	FLANGE LOCKNUT (1/4-NC)	
4.	362-623	1	COIL COVER BACK	
5.	216-023	1	CURRENT TRANSFORMER	
6.	362-718	1	COIL COVER FRONT	
7.	105-845	4	FLANGE LOCKNUT (3/8-NC)	
8.	116-376	4	SPACER	
9.	116-283	4	RUBBER WASHER	
10.	106-176	1	CONDUIT LOCKNUT (1/2-NPT)	
11.	215-853	1	CORD GRIP CONNECTOR	
12.	105-297	4	BOLT (1/4-NC X 3-1/4")	
13.	215-784	1	CABLE	
14.	215-843	3	RING TERMINAL (#10)	

NOT SHOWN:

FOOTNOTES:

1. D - GREEN OR BLUE (TEST), E - BLACK OR SHIELD (COMMON), F - WHITE OR BROWN
2. BRACKET IS USED FOR BOTH P40 AND P80, DIFFERENT MOUNTING HOLES ARE USED FOR EACH ASSEMBLY.

NOTE:

ELECTRICAL DIAGRAM

P40, P80
PRESENT PRODUCTION

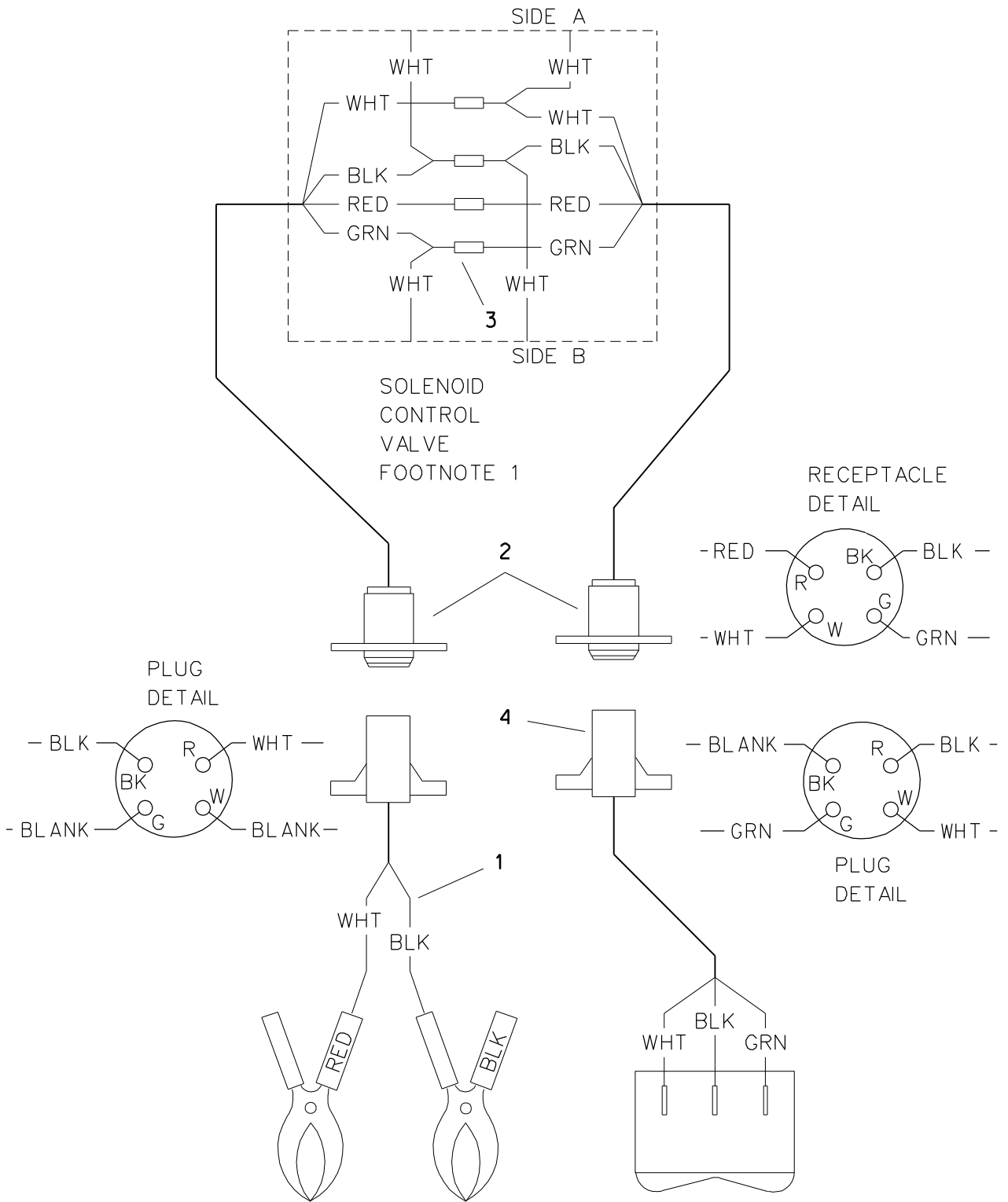

ELECTRICAL DIAGRAM

P40, P80

PRESENT PRODUCTION

REF PART

NO. NUMBER QTY DESCRIPTION REMARKS

REF NO.	PART NUMBER	QTY	DESCRIPTION	REMARKS
1.	215-983	1	POWER HARNESS	
	215-737		ALLIGATOR CLIPS (PAIR)	
2.	215-982	2	SOLENOID CABLE	
3.	215-478	4	BUTT CONNECTOR (16 GA)	
4.	217-065	1	REMOTE CONTROL HANDLE	
	215-077		ROCKER SWITCH	

FOOTNOTES

1 - SEE PAGE ENTITLED "P40 AND P80 WITH SOLENOID CONTROL VALVE".

COIL BRACKET
EARLY STYLE

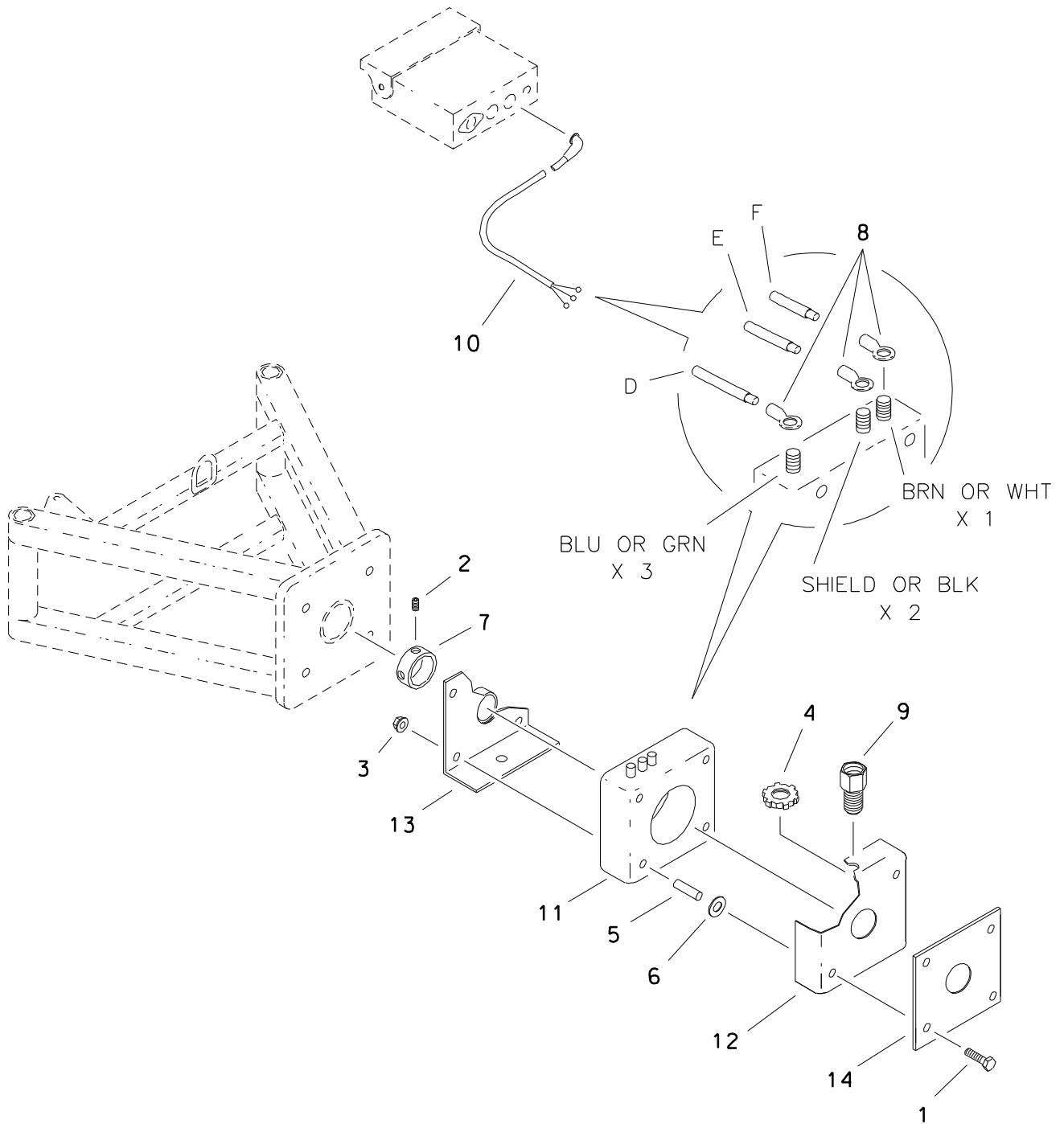

COIL BRACKET EARLY STYLE

REF NO.	PART NUMBER	QTY	DESCRIPTION	REMARKS
	<u>354-208</u>		CURRENT TRANSFORMER	INCL REF NO.'S 1 THRU 14
1.	105-297	4	BOLT (1/4-NC X 3-1/4")	
2.	105-716	2	SETSCREW (3/8-NC X 1/2")	
3.	105-832	4	FLANGE LOCKNUT	
4.	106-176	1	CONDUIT LOCKNUT	
5.	116-376	4	SPACER	
6.	116-283	4	WASHER	
7.	184-138	1	BUSHING	
8.	215-476	3	RING TERMINAL	
9.	215-853	1	CORD GRIP CONNECTOR	
10.	215-784	1	CABLE	INCL REF NO. 8
11.	<u>216-023</u>	1	CURRENT TRANSFORMER	SEE FOOTNOTE 1.
12.	354-205	1	COIL COVER	
13.	354-206	1	COIL BRACKET	
14.	354-207	1	COIL PLATE	

FOOTNOTES

1. REF 11 OBSOLETE. 216-023 REPLACED WITH 101-149.

NOTES:

ACCESSORIES

P40 PILOT HEADS OLD STYLE

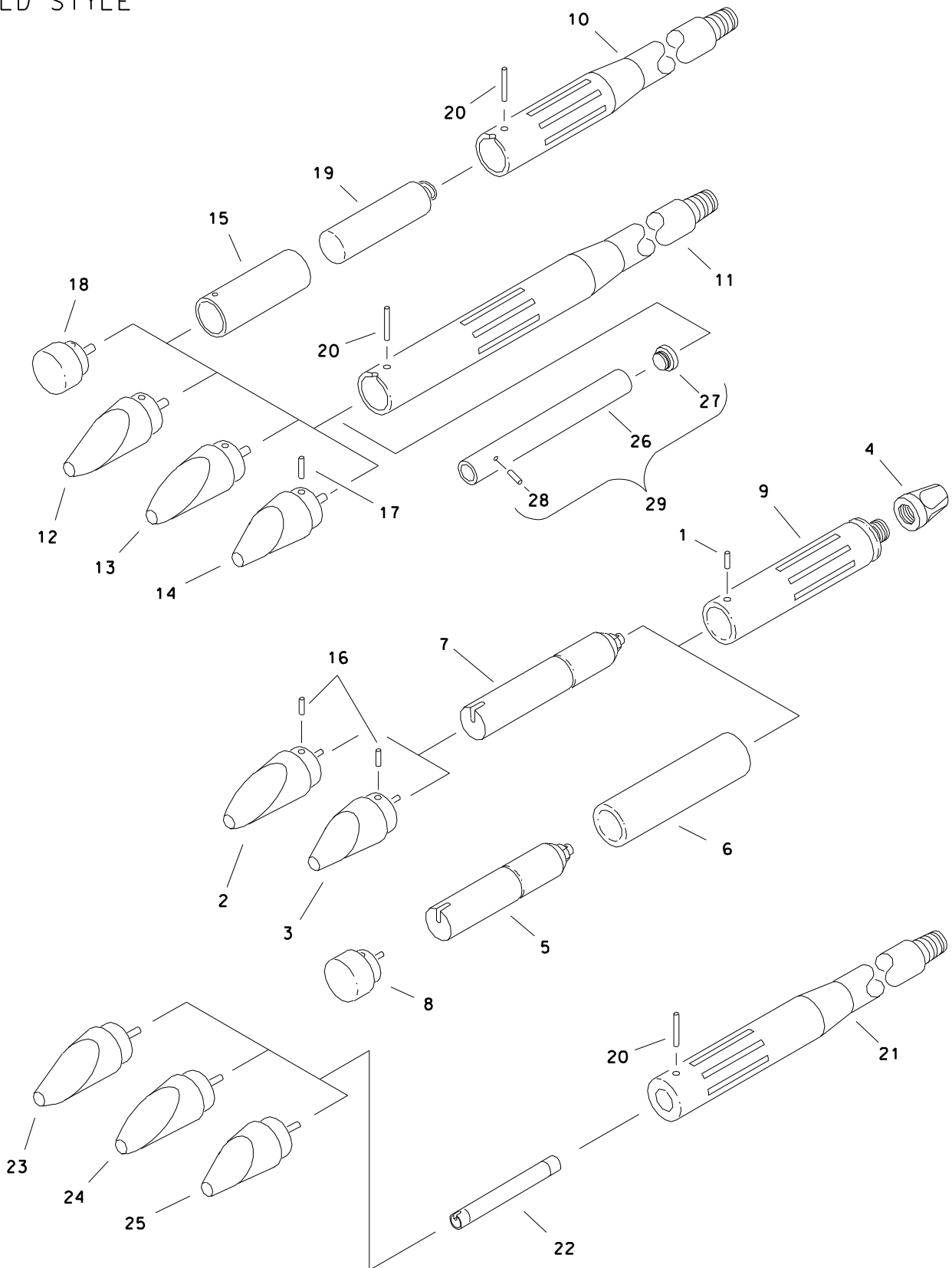

P40 PILOT HEADS OLD STYLE

REF NO.	PART NUMBER	QTY	DESCRIPTION	REMARKS
1.	105-519	AR	ROLL PIN (3/8" X 1-1/2")	
2.	354-124	AR	AGGRESSIVE DIRECTIONAL HEAD	5" LG W/ 1.11" DIA ON SMALL END; INCL REF NO. 16
	105-535		ROLL PIN (1/8" X 5/8")	
3.	354-123	AR	STANDARD DIRECTIONAL HEAD	4" LG W/ 1.11" DIA ON SMALL END; INCL REF NO. 16
	105-535		ROLL PIN (1/8" X 5/8")	
4.	110-421		THERMOPLASTIC CAP (1-1/16")	
5.	220-025	AR	DIRECTIONAL SONDE	1.08" DIA X 7.97" LG
6.	354-125	AR	DETECTION SONDE HOUSING SLEEVE	
7.	220-010	AR	DETECTION SONDE	0.87" DIA X 7.125" LG
	215-263		BATTERY (1.5V, AA, ALKALINE)	
8.	354-122	AR	DETECTION HEAD (1.11" DIA)	INCL REF NO. 16
9.	354-085	AR	SONDE HOUSING (.98" DIA)	SEE FOOTNOTE 1
	354-121	AR	SONDE HOUSING ASSY (1.11" DIA)	INCL REF NO. 1; SEE FOOTNOTE 1
	354-082		SONDE HOUSING ASSY (1.11" DIA)	INCL REF NO.'S 1 AND 9; SEE FOOTNOTE 1
	354-119		DETECTION SONDE HOUSING ASSY (1.11" ID)	INCL REF NO.'S 1, 4, 6 AND 9
	354-120		DIRECTION SONDE HOUSING ASSY (1.11" ID)	INCL REF NO.'S 1, 4 AND 9
10.	354-233	AR	BEACON HOUSING - FLEX (1.190"-M)	
11.	357-277	AR	BEACON HOUSING - FLEX (1.190"-M)	SEE FOOTNOTE 2
12.	354-104	AR	DIRECTIONAL HEAD	STANDARD; 2.25"OD X 7"LG; INCL REF NO.'S 17
13.	354-105	AR	DIRECTIONAL HEAD	AGGRESSIVE; 2.25"OD X 7.5"LG; INCL REF NO.'S 17
14.	354-106	AR	DIRECTIONAL HEAD	LESS AGGRESS.; 2.25"OD X 6"LG; INCL REF NO.'S 17
15.	354-213	AR	BEACON HOUSING SLEEVE	
16.	105-535	AR	ROLL PIN (1/8" X 5/8")	
17.	105-524	AR	ROLL PIN (1/8" X 3/4")	
18.	354-108	AR	DETECTION HEAD	
19.	102-016	AR	BEACON, 80B/R	
	102-085	AR	BEACON, 83B/R	
20.	105-548	AR	ROLL PIN (1/2" X 2-1/4" LG)	
21.	359-085	AR	SBR BEACON HOUSING - FLEX	SEE FOOTNOTE 2
22.	102-092	AR	BEACON, SBR	
23.	359-083	AR	SBR STD DIRECTIONAL PILOT HEAD	INCL REF NO. 17
24.	359-082	AR	SBR AGGRESSIVE PILOT HEAD	INCL REF NO. 17
25.	359-084	AR	SBR LESS AGGRESSIVE PILOT HEAD	INCL REF NO. 17
26.	178-704	1	SLEEVE	USED FOR SBPR BEACONS TO ALLOW USE IN OLD STYLE 85 HOUSINGS.
27.	400-643	1	PLUG	USED FOR SBPR BEACONS TO ALLOW USE IN OLD STYLE 85 HOUSINGS.
28.	105-553	1	ROLL PIN (1/8" X 1/2")	85 HOUSINGS.
29.	400-902	1	SLEEVE ASSEMBLY	INCL REF NO.'S 27, 28 AND 29

NOT SHOWN:

256-628 AR EPOXY

FOOTNOTES

1 - EARLY STYLE PILOT HEAD, SONDE HOUSING AND HOUSING ASSEMBLY (REF NO.'S 8 AND 9), IDENTIFIED BY PILOT HEAD WITH A .98" DIA ON THE SMALLER END, ARE NO LONGER AVAILABLE.

IF REPLACEMENT IS REQUIRED REPLACE BOTH PILOT HEAD AND SONDE HOUSING WITH NEW STYLE WHICH USES PILOT HEAD WITH 1.11" DIA ON THE SMALLER END.

2 - USE EPOXY (256-628 OR EQUIVALENT) TO SEAL WINDOWS.

P40 PILOT HEADS NEW STYLE

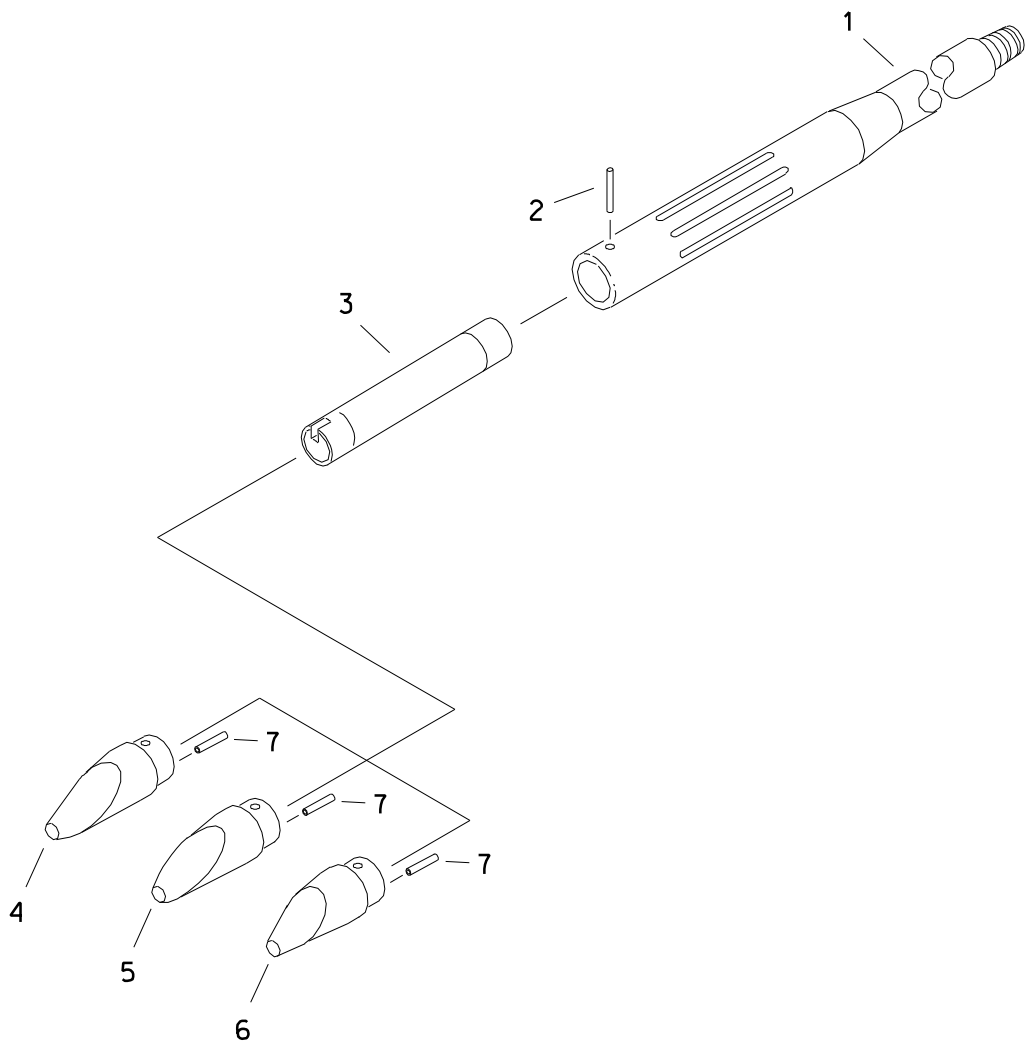

P40 PILOT HEADS NEW STYLE

REF NO.	PART NUMBER	QTY	DESCRIPTION	REMARKS
1.	400-900 AR		P40 86B BEACON HOUSING ASSY	SEE FOOTNOTE 1
2.	105-548 AR		ROLL PIN (1/2" X 2-1/4" LG)	
3.	102-152	1	BEACON, 86B	
4.	400-897	1	86 STANDARD PILOT HEAD	INCL REF NO. 7
5.	400-898	1	86 AGGRESSIVE PILOT HEAD	INCL REF NO. 7
6.	400-899	1	86 LESS AGGRESSIVE PILOT HEAD	INCL REF NO. 7
7.	105-524	1	ROLL PIN (1/8" X 3/4")	

NOT SHOWN:

250-023 AR EPOXY SEE FOOTNOTE 1

FOOTNOTES

1. USE EPOXY (250-023 OR EQUIVALENT) TO SEAL WINDOWS. (250-025 CAULKING GUN ADAPTER REQUIRED)

P80 PILOT HEADS, BEACONS AND SONDES OLD STYLE

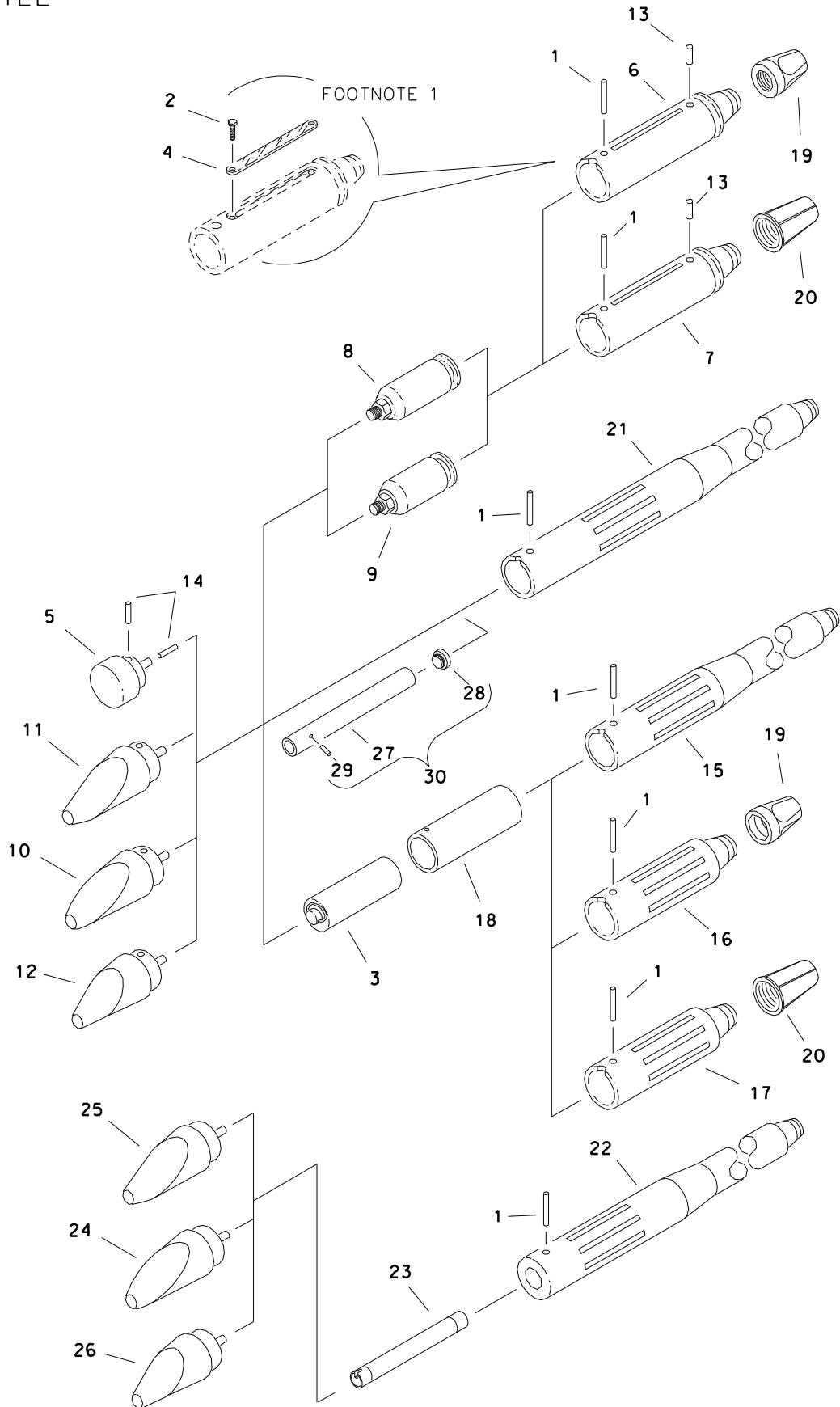

P80 PILOT HEADS, BEACONS AND SONDES OLD STYLE

REF NO.	PART NUMBER	QTY	DESCRIPTION	REMARKS
1.	105-548	AR	ROLL PIN (1/2" X 2-1/4")	
2.	106-088	AR	BOLT (1/4-NC X 3/8", CSK SLT HD)	
3.	102-085	AR	BEACON 83B/R	
	102-016	AR	BEACON 80B/R	
4.	115-767	AR	WINDOW PLATE	
5.	354-088	AR	DETECTION PILOT HEAD	
6.	354-089	AR	SONDE HOUSING (AP#V-0.040)	INCL REF NO.'S 13 AND 19; SEE FOOTNOTE 1, 3 AND 4
7.	354-156	AR	SONDE HOUSING (AP#V-0.055)	INCL REF NO.'S 13, 19 AND 20; SEE FOOTNOTE 2 AND 3
8.	354-090	AR	DETECTION SONDE	
9.	354-103	AR	DIRECTIONAL SONDE	
10.	354-104	AR	STD DIRECTIONAL PILOT HEAD (7")	INCL REF NO.'S 14; SEE FOOTNOTE 2
11.	354-105	AR	AGGRESSIVE PILOT HEAD (7.5")	INCL REF NO.'S 14; SEE FOOTNOTE 2
12.	354-106	AR	LESS AGGRESSIVE PILOT HEAD (6")	INCL REF NO.'S 14; SEE FOOTNOTE 2
13.	105-524	AR	ROLL PIN (1/8" X 3/4")	
14.	500-212	AR	ROLL PIN (3/16" X 1/2")	
15.	354-227	AR	BEACON HOUSING-FLEX (AP#V-0.055)	SEE FOOTNOTE 2
	357-198	AR	RD HOUSING-FLEX (AP#V-0.055)	
16.	354-214	AR	BEACON HOUSING (AP#V-0.040)	SEE FOOTNOTE 1
17.	354-212	AR	BEACON HOUSING (AP#V-0.055)	INCL REF NO.'S 20; SEE FOOTNOTE 2
18.	354-213	AR	BEACON HOUSING SLEEVE	
19.	110-422	AR	CAP (1-3/8")	
20.	110-858	AR	THD PROTECTION CAP (1.41"-6-FM-API,DS)	
21.	357-191	AR	BEACON HOUSING - FLEX	SEE FOOTNOTE 4
22.	359-081	AR	SBR BEACON HOUSING - FLEX	SEE FOOTNOTE 4
23.	102-092	AR	BEACON, SBR	
24.	359-083	AR	SBR STD DIRECTIONAL PILOT HEAD	INCL REF NO. 13; SEE FOOTNOTE 2
25.	359-082	AR	SBR AGGRESSIVE PILOT HEAD	INCL REF NO. 13; SEE FOOTNOTE 2
26.	359-084	AR	SBR LESS AGGRESSIVE PILOT HEAD	INCL REF NO. 13; SEE FOOTNOTE 2
27.	178-704	1	SLEEVE	USED FOR SBPR BEACONS TO ALLOW USE IN OLD STYLE 85 HOUSINGS
28.	400-643	1	PLUG	USED FOR SBPR BEACONS TO ALLOW USE IN OLD STYLE
29.	105-553	1	ROLL PIN (1/8" X 1/2")	85 HOUSINGS
30.	400-902	1	SLEEVE ASSEMBLY	INCL REF NO.'S 27, 28 AND 29
NOT SHOWN:				
	256-628	AR	EPOXY	

FOOTNOTES

- 1 - EARLY STYLE SONDE, WITH WINDOW, IS NO LONGER AVAILABLE. REPLACEMENTS WILL BE OF SLOTTED DESIGN (AS DEPICTED IN MAIN ILLUSTRATION). SEE FOOTNOTE 2.
- 2 - EARLY STYLE SONDES HAD AP#V-0.040 THREADS. DO NOT MIX WITH PARTS THAT HAVE AP#V-0.055 THREADS.
- 3 - PRESENT SONDES HAVE AP#V-0.055 THREADS. DO NOT MIX WITH PARTS THAT HAVE AP#V-0.040 THREADS.
- 4 - USE EPOXY (256-628 OR EQUIVALENT) TO SEAL WINDOWS.

P80 PILOT HEADS

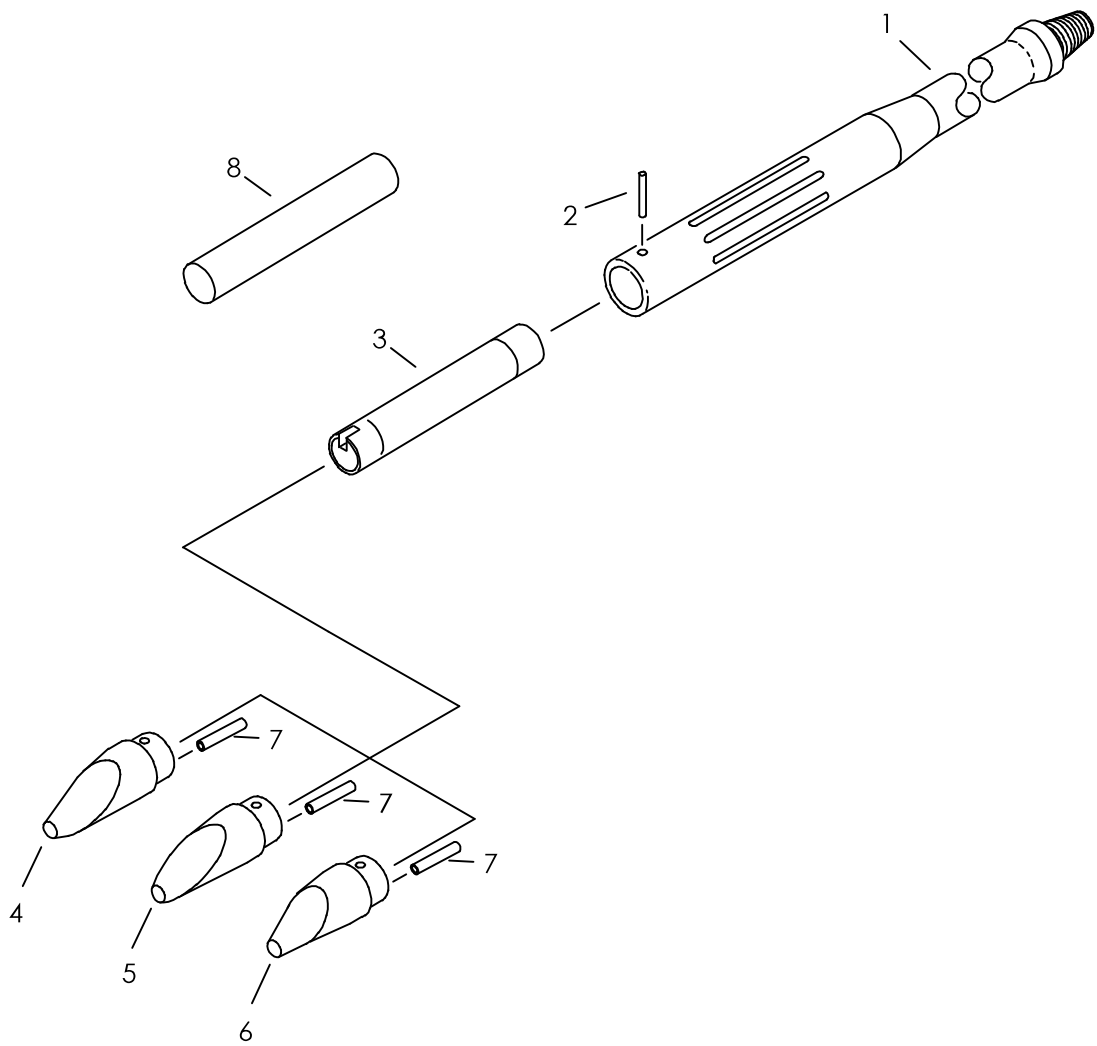

P80 PILOT HEADS

REF NO.	PART NUMBER	QTY	DESCRIPTION	REMARKS
1.	400-901	AR	P80 86B BEACON HOUSING ASSY	SEE FOOTNOTE 1
2.	105-548	AR	ROLL PIN (1/2" X 2-1/4" LG)	
3.	102-152	1	BEACON, 86B	
4.	400-897	1	86 STANDARD PILOT HEAD	INCL REF NO. 7
5.	400-898	1	86 AGGRESSIVE PILOT HEAD	INCL REF NO. 7
6.	400-899	1	86 LESS AGGRESSIVE PILOT HEAD	INCL REF NO. 7
7.	105-510	1	ROLL PIN (1/4" X 1-1/2")	
8.	400-902	1	SLEEVE ASSEMBLY	USE WITH 88B ONLY

NOT SHOWN:

250-023 AR EPOXY

SEE FOOTNOTE 1

FOOTNOTES:

I. USE EPOXY (250-023 OR EQUIVALENT) TO SEAL WINDOWS. (250-025 CAULKING GUN ADAPTER REQUIRED).

NOTE:

PUSH RODS P40

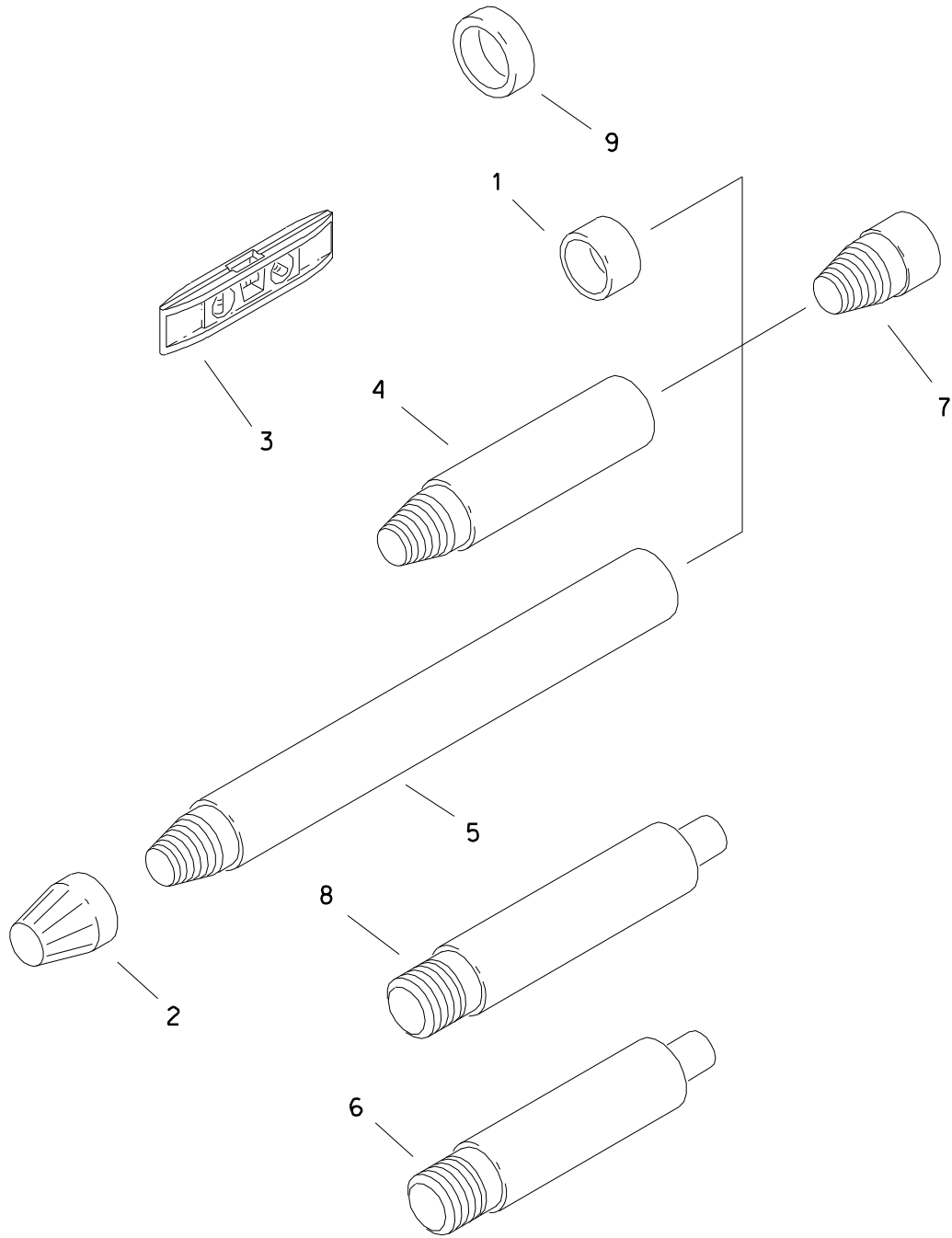

PUSH RODS

P40

REF NO.	PART NUMBER	QTY	DESCRIPTION	REMARKS
1.	110-420		PLASTIC CAP (1-3/8" X 5/8" LG)	P40
2.	110-421		PLASTIC CAP (1-1/16")	P40
3.	259-131	AR	TORPEDO LEVEL	
4.	354-001	AR	24" PUSH ROD	P40 PAINTED; INCL REF NO.'S 1 AND 2
	354-228	AR	24" PUSH ROD	P40 UNPAINTED; INCL REF NO.'S 1 AND 2
	354-081	AR	36" PUSH ROD	P40 PAINTED; INCL REF NO.'S 1 AND 2
	354-229	AR	36" PUSH ROD	P40 UNPAINTED; INCL REF NO.'S 1 AND 2
5.	354-002	AR	48" PUSH ROD	P40 PAINTED; INCL REF NO.'S 1 AND 2
	354-230	AR	48" PUSH ROD	P40 UNPAINTED; INCL REF NO.'S 1 AND 2
6.	354-003	AR	PUSH ROD ADAPTER	P40 SEE FOOTNOTE 1
7.	354-004	AR	PUSH ROD PILOT	
8.	354-028	AR	PUSH ROD ADAPTER	P40 SEE FOOTNOTE 2
9.	157-551	AR	WIPER SEAL (1.375" ID)	P40

FOOTNOTES

1 - ADAPTS PUSH RODS TO BOR-TEC RODS.

2 - ADAPTS PUSH RODS TO ELEPHANT RODS.

PUSH RODS P80

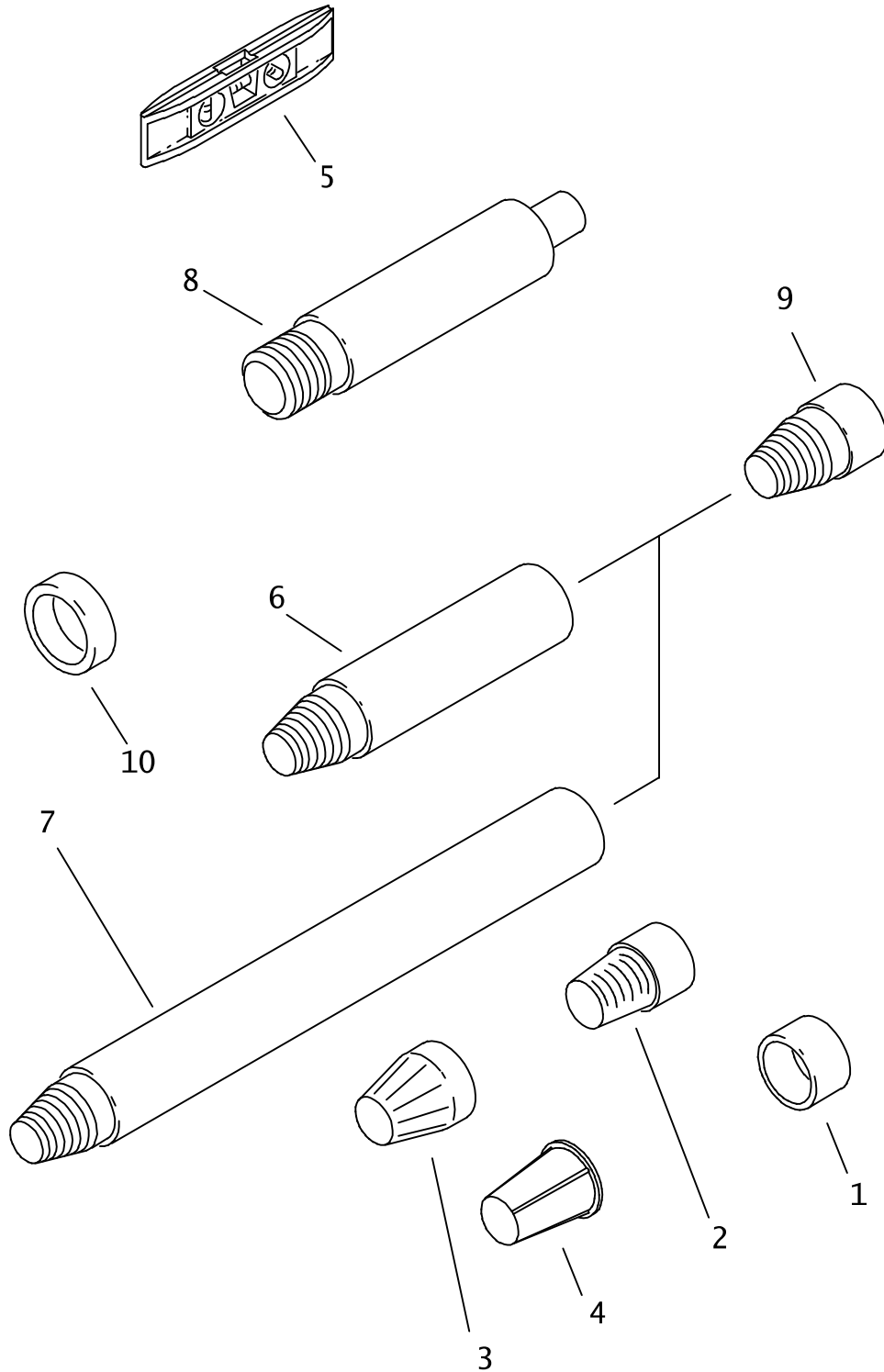

PUSH RODS

P80

REF NO.	PART NUMBER	QTY	DESCRIPTION	REMARKS
1.	110-142	AR	PLASTIC CAP (1-3/4")	
2.	356-207	AR	THD PROTECTION CAP (1.41" BOX)	
3.	110-422	AR	PLASTIC CAP (1-3/8" X 2-13/32")	
4.	356-206	AR	THD PROTECTION CAP (1.41" PIN)	
5.	259-131	AR	TORPEDO LEVEL	
6.	354-146	AR	24" PUSH ROD	
	354-231	AR	24" PUSH ROD	
7.	354-149	AR	48" PUSH ROD	
	354-232	AR	48" PUSH ROD	
8.	354-150	AR	PUSH ROD ADAPTER	
	354-147	AR	PUSH ROD ADAPTER	
	354-148	AR	PUSH ROD ADAPTER	
9.	354-033	AR	PUSH ROD PILOT	
	354-157	AR	PUSH ROD PILOT	
10.	157-550	AR	U-SEAL (1.75" ID)	

NOT SHOWN:

FOOTNOTES:

1. API #V-0.040 MALE THREAD (P80) CAN BE IDENTIFIED BY LENGTH, SHOULDER TO END OF PIN = 1.375".
2. API #V-0.055 MALE THREAD (P80) CAN BE IDENTIFIED BY LENGTH, SHOULDER TO END OF PIN = 2.00".
3. API #V-0.040 FEMALE THREADS (P80) CAN BE IDENTIFIED BY THE I.D. AT THE FACE, I.D. = 1.532 DIA.
4. API #V-0.055 FEMALE THREADS (P80) CAN BE IDENTIFIED BY THE I.D. AT THE FACE, I.D. = 1.427".

NOTE:

PULLING TOOLS

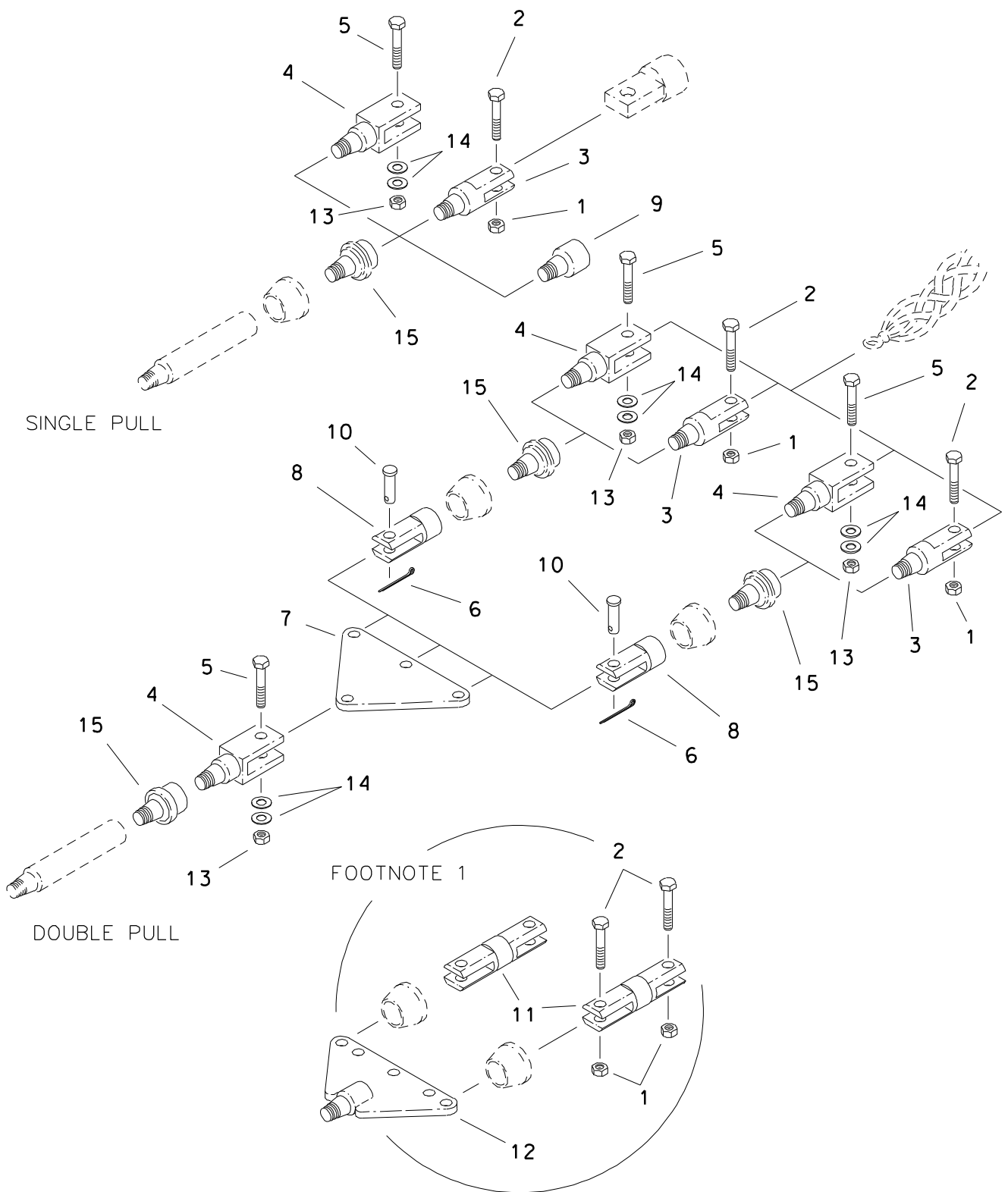

PULLING TOOLS

REF NO.	PART NUMBER	QTY	DESCRIPTION	REMARKS
1.	105-065	AR	LOCKNUT (1/2-NC)	
2.	105-871	AR	BOLT (1/2-NC X 2")	
3.	354-062	AR	CLEVIS ADAPTER	API #V-0.040 MALE (P80) FN 4
	354-161	AR	CLEVIS ADAPTER	API #V-0.055 MALE (P80) FN 5
4.	354-137	AR	LARGE CLEVIS	API #V-0.040 MALE (P80) FN 4
	354-163	AR	LARGE CLEVIS	API #V-0.055 MALE (P80) FN 5
	354-236	AR	LARGE CLEVIS	API #V-0.055 MALE (P80) FN 5
5.	110-501	AR	CLEVIS PIN (1" DIA X 3" LG)	
	105-559	AR	BOLT (1-NC X 4-45/64", GD8)	
6.	105-506	AR	COTTER PIN (.188" X 1.5")	
7.	354-140	AR	PULLING ADAPTER	
	354-234	AR	PULLING ADAPTER	
8.	354-143	AR	CLEVIS ADAPTER	API #V-0.040 FEMALE (P80) FN 4
	354-165	AR	CLEVIS ADAPTER	API #V-0.055 FEMALE (P80) FN 5
9.	354-141	AR	BELL STOP ADAPTER FN 6 & 4	API #V-0.040 FEMALE (P40)/API #V-0.040 MALE (P80)
	354-160	AR	BELL STOP ADAPTER FN 6 & 5	API #V-0.040 FEMALE (P40)/API #V-0.055 MALE (P80)
10.	110-500	AR	CLEVIS PIN (1" DIA X 2" LG)	
11.	354-063	AR	DOUBLE CLEVIS ADAPTER	
12.	354-064	AR	PULLING ADAPTER	
13.	105-367	AR	LOCKNUT	
14.	105-930	AR	WASHER	
15.	354-060	AR	BELL STOP - FOOTNOTE 3 & 7	API #V-0.040 MALE (P40)/API #V-0.040 FEMALE (P80)
	354-158	AR	BELL STOP - FOOTNOTE 3 & 8	API #V-0.040 MALE (P40)/API #V-0.055 FEMALE (P80)
	354-061	AR	BELL STOP - FOOTNOTE 4 & 7	API #V-0.040 MALE (P80)/API #V-0.040 FEMALE (P80)
	354-159	AR	BELL STOP - FOOTNOTE 5 & 8	API #V-0.055 MALE (P80)/API #V-0.055 FEMALE (P80)
NOT SHOWN:				
	157-550		U-SEAL	P80
	157-551		WIPER SEAL	P40

FOOTNOTES

- 1 - EARLY STYLE PULLING ADAPTER AND DOUBLE CLEVIS.
- 2 - [XXX-XXX] = OBSOLETE
- 3 - API #V-0.040 MALE THREAD (P40) CAN BE IDENTIFIED BY LENGTH, SHOULDER TO END OF PIN = 1.25IN.
- 4 - API #V-0.040 MALE THREAD (P80) CAN BE IDENTIFIED BY LENGTH, SHOULDER TO END OF PIN = 1.375IN.
- 5 - API #V-0.055 MALE THREAD (P80) CAN BE IDENTIFIED BY LENGTH, SHOULDER TO END OF PIN = 2.00IN.
- 6 - API #V-0.040 FEMALE THREADS (P40) CAN BE IDENTIFIED BY THE I.D. AT THE FACE, I.D. = 1.204 DIA.
- 7 - API #V-0.040 FEMALE THREADS (P80) CAN BE IDENTIFIED BY THE I.D. AT THE FACE, I.D. = 1.532 DIA..
- 8 - API #V-0.055 FEMALE THREADS (P80) CAN BE IDENTIFIED BY THE I.D. AT THE FACE, I.D. = 1.427 DIA.

PULLING TOOLS ACCESSORIES

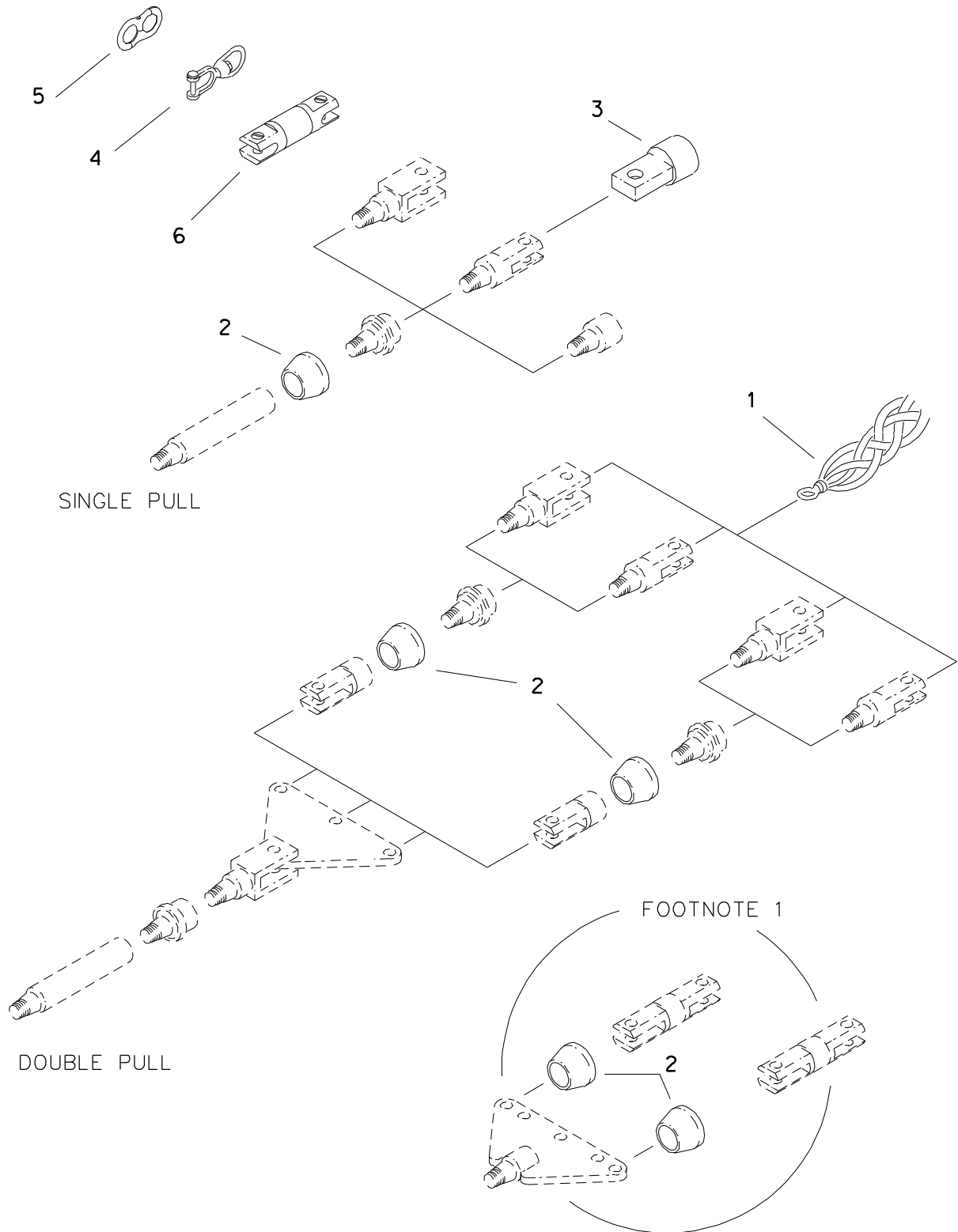

PULLING TOOLS ACCESSORIES

REF NO.	PART NUMBER	QTY	DESCRIPTION	REMARKS
1.	185-901	AR	PULLING GRIP (3/8" TO 1/2")	INCLUDES SWIVEL
	185-902	AR	PULLING GRIP (1/2" TO 3/4")	INCLUDES SWIVEL
	185-903	AR	PULLING GRIP (3/4" TO 1-1/4")	INCLUDES SWIVEL
	185-904	AR	PULLING GRIP (1-1/4" TO 2")	INCLUDES SWIVEL
	185-906	AR	PULLING GRIP (2" TO 2-3/4")	INCLUDES SWIVEL
	185-907	AR	PULLING GRIP (2-3/4" TO 3-1/2")	INCLUDES SWIVEL
	185-913	AR	PULLING GRIP (3-1/2" TO 4-1/4")	INCLUDES SWIVEL
	185-914	AR	PULLING GRIP (4-1/4" TO 4-3/4")	INCLUDES SWIVEL
	185-917	AR	PULLING GRIP (3/4" TO 1-1/2")	
	185-918	AR	PULLING GRIP (1-1/4" TO 2")	
	185-919	AR	PULLING GRIP (2" TO 2-3/4")	
	185-920	AR	PULLING GRIP (2-3/4" TO 3-1/2")	
	185-921	AR	PULLING GRIP (3-1/2" TO 4-1/4")	
	185-922	AR	PULLING GRIP (3/4" TO 1-1/4")	HEAVY DUTY
	185-923	AR	PULLING GRIP (1-1/4" TO 2")	HEAVY DUTY
	185-924	AR	PULLING GRIP (2" TO 2-3/4")	HEAVY DUTY
	185-925	AR	PULLING GRIP (2-3/4" TO 3-1/2")	HEAVY DUTY
	185-926	AR	PULLING GRIP (3-1/2" TO 4-1/4")	HEAVY DUTY
2.	354-005	AR	EXPANDER (3-1/2")	
	354-006	AR	EXPANDER (4-1/2")	
	354-007	AR	EXPANDER (5-1/2")	
	354-008	AR	EXPANDER (6-5/8")	
	354-057	AR	EXPANDER (8-5/8")	
	354-058	AR	EXPANDER (10-3/4")	
	354-059	AR	EXPANDER (12-3/4")	
3.	354-046	AR	PIPE ADAPTER (1-NPT)	
	354-047	AR	PIPE ADAPTER (1-1/2-NPT)	
	354-048	AR	PIPE ADAPTER (2-NPT)	
	354-049	AR	PIPE ADAPTER (2-1/2-NPT)	
	354-050	AR	PIPE ADAPTER (3-NPT)	
	354-051	AR	PIPE ADAPTER (4-NPT)	
	354-052	AR	PIPE ADAPTER (6-NPT)	
4.	185-927	AR	JAW AND EYE SWIVEL (5/16")	
	185-928	AR	JAW AND EYE SWIVEL (3/8")	
	185-929	AR	JAW AND EYE SWIVEL (1/2")	
5.	185-930	AR	SWING LINK (7/16")	
	185-931	AR	SWING LINK (9/16")	
6.	185-932	AR	DIRECTIONAL BORING SWIVEL	9,000 LB WORK LOAD
	185-933	AR	DIRECTIONAL BORING SWIVEL	12,000 LB WORK LOAD

FOOTNOTES

ROD GRABBER

P40/P80

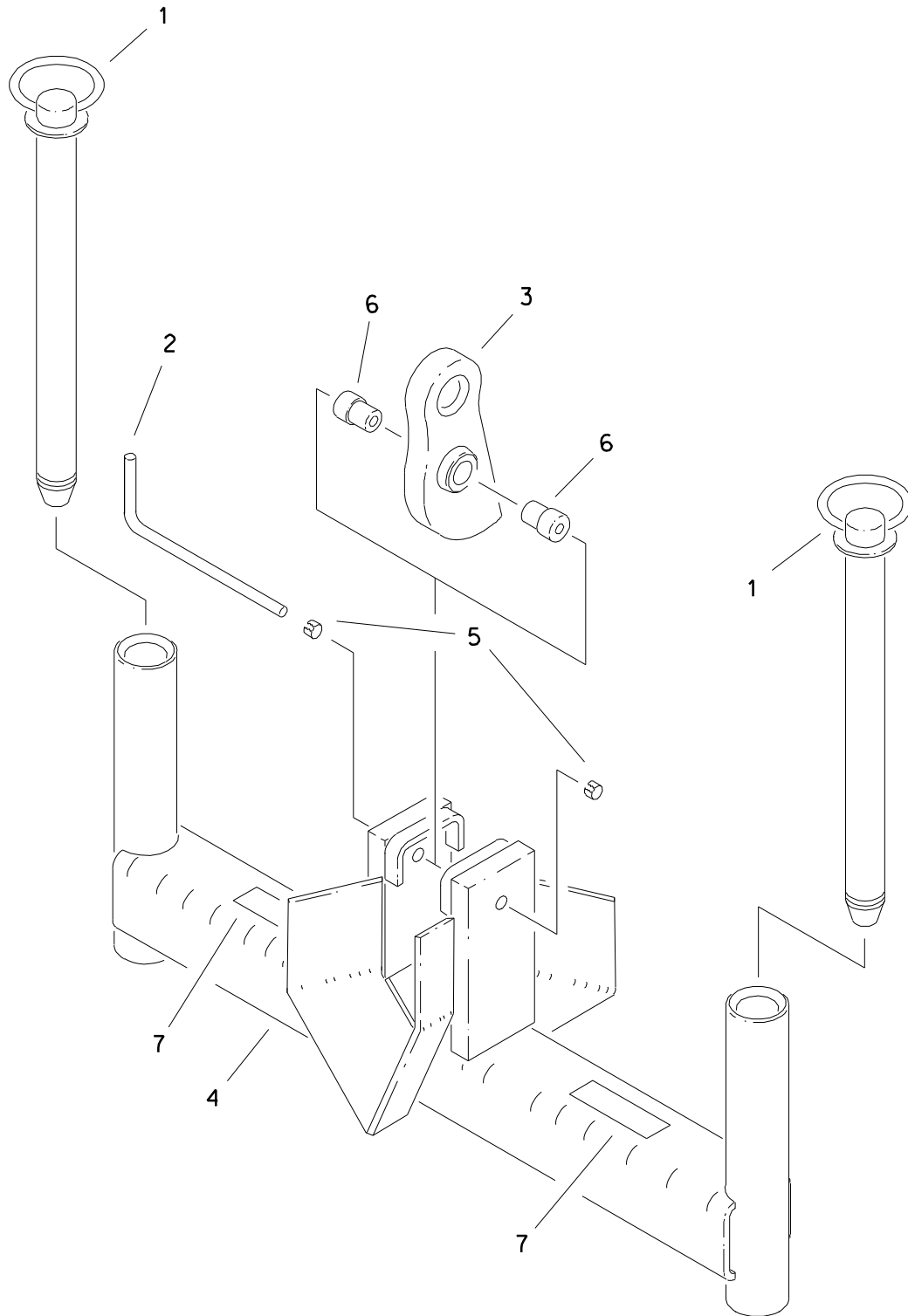

ROD GRABBER P40/P80

REF NO.	PART NUMBER	QTY	DESCRIPTION	REMARKS
	190-567		ROD GRABBER KIT	INCL REF NO.S 1 THRU 7
1.	183-676	2	HITCH PIN	
2.	179-011	1	LOCK PIN	SEE FOOTNOTE #1
3.	354-244	1	CAM STOP	
4.	354-241	1	CHANNEL SUPPORT	
5.	125-816	2	SPLIT BUSHING	
6.	183-979	2	SPACER PIN	
7.	274-435	2	ROD GRABBER OPERATIONS DECAL	

FOOTNOTES

1. USE CMW P/N 179-011 ONLY, DO NOT SUBSTITUTE

NOTES:

MISCELLANEOUS

SAE Bolt and Nut Torque Value Chart

Grade 5: UNC or UNF Thread

Size	Hex nut, or bolt tapped into hex nut, or d&t hole		Hex top deformed locknut		Flange nut, locknut, or bolt tapped into flange nut or d&t* hole	
	ft•lb	N•m	ft•lb	N•m	ft•lb	N•m
1/4	12	16	8	11	20	27
5/16	25	34	15	20	45	60
3/8	40	54	25	34	75	100
7/16	65	90	40	55	125	170
1/2	100	135	60	80	190	260
9/16	150	200	90	125	270	370
5/8	200	270	120	165	370	500
3/4	350	475	210	285	650	880
7/8	560	760	340	460	1250	1425
1	840	1140	500	680	1580	2145
1-1/8	1030	1400	320	840	1950	3645
1-1/4	1460	1980	880	1195	2760	3475

Grade 8: UNC or UNF Thread

Size	Hex nut, or bolt tapped into hex nut, or d&t hole		Hex top deformed locknut		Flange nut, locknut, or bolt tapped into flange nut or d&t* hole	
	ft•lb	N•m	ft•lb	N•m	ft•lb	N•m
1/4	14	19	10	14	24	33
5/16	30	40	18	25	50	70
3/8	55	73	35	50	90	125
7/16	85	115	50	70	140	190
1/2	130	175	80	110	220	300
9/16	190	260	110	150	310	420
5/8	260	355	160	245	430	585
3/4	450	610	270	365	750	1015
7/8	730	990	440	600	1210	1640
1	1090	1480	650	880	1320	2465
1-1/8	1550	2100	930	1260	2580	3500
1-1/4	2180	2955	1310	1780	3640	4935

*drilled and tapped

Metric Bolt and Cap Screw Torque Values

Size	Class 4.8				Class 8.8 and 9.8				Class 10.9				Class 12.9			
	Lubricated		Dry		Lubricated		Dry		Lubricated		Dry		Lubricated		Dry	
	N•m	ft•lb	N•m	ft•lb	N•m	ft•lb	N•m	ft•lb	N•m	ft•lb	N•m	ft•lb	N•m	ft•lb	N•m	ft•lb
M6	4.8	3.5	6	4.5	9	6.5	11	8.5	13	9.5	17	12	15	11.5	19	14.5
M8	12	8.5	15	11	22	16	28	20	32	24	40	30	37	28	47	35
M10	23	17	29	21	43	32	55	40	63	47	80	60	75	55	95	70
M12	40	29	50	37	75	55	95	70	110	80	140	105	130	95	165	120
M14	63	47	80	60	120	88	150	110	175	130	225	165	205	150	260	190
M16	100	73	125	92	190	140	240	175	275	200	350	225	320	240	400	300
M18	135	100	175	125	260	195	330	250	375	275	475	350	440	325	560	410
M20	190	140	240	180	375	275	475	350	530	400	675	500	625	460	800	580
M22	260	190	330	250	510	375	650	475	725	540	925	675	850	625	1075	800
M24	330	250	425	310	650	475	825	600	925	675	1150	850	1075	800	1350	1000
M27	490	360	625	450	950	700	1200	875	1350	1000	1700	1250	1600	1150	2000	1500
M30	675	490	850	625	1600	950	1650	1200	1850	1350	2300	1700	2150	1600	2700	2000
M33	900	675	1150	850	1750	1300	2200	1650	2500	1850	3150	2350	2900	2150	3700	2750
M36	1150	850	1450	1075	2250	1650	2850	2100	3200	2350	4050	3000	3750	2750	4750	3500

Do not use these values if a different torque value or tightening procedure is given for specific application. Torque values listed are for general use only. Check tightness of fasteners periodically.

Shear bolts are designed to fail under predetermined loads. Always replace shear bolts with identical property class fasteners.

Fasteners should be replaced with the same or higher property class. If higher property class fasteners are used, these should only be tightened to strength of original.

Make sure fastener threads are clean and that the threads are properly started. This will prevent them from cross threading or galling when tightened.

Tighten plastic insert or crimped type steel locknuts to approximately 50% of dry torque indicated on chart. Apply torque to the nut - not the bolt head. Tighten toothed or serrated type locknuts to full torque value.

LUBRICATED means coated with lubricant. DRY means plain or zinc plated without any type of lubricant.

Hydraulic Cylinder Bolt Torque Chart

Bolt Size (inch)	Bolt Part No.	Cylinder Repair Kit Part No.	Torque (ft•lb)	Torque (N•m)
1/2	106-096	190-165	90-100	120-135
5/8	106-097	190-166 & 190-169	180-200	245-270
3/4	106-098	190-167 & 190-170	290-325	395-440
7/8	106-122	190-172 & 190-174	410-640	550-625
1	106-145	190-175 & 190-189	630-700	855-950
1-1/8	106-146	190-177	770-850	1045-1170

As a general rule:

- 1/2-inch bolts are used in cylinders with 1-inch rods
- 5/8-inch bolts are used in cylinders with 1 1/4-inch rods
- 3/4-inch bolts are used in cylinders with 1 1/2-inch rods
- 7/8-inch bolts are used in cylinders with 1 3/4-inch rods
- 1-inch bolts are used in cylinders with 2-inch rods (one with 1 3/4-inch)
- 1-1/8-inch bolts are used in cylinders with 2-1/4-inch rods

IMPORTANT: Do not reuse cylinder piston bolts when rebuilding a hydraulic cylinder. Each cylinder repair kit contains a new bolt. Use it. Lubricate lightly and torque to value shown on chart.

SAE & ORS Hydraulic Fitting Replacement O-Ring Chart

Fraction Size	Dash Size	SAE (Port Seal O-Ring)		ORS (Face Seal O-Ring)	
		Thread Size	O-Ring P/N	Thread Size	O-Ring P/N
1/16	1	NA	NA	NA	NA
1/8	2	5/16 - 24	NA	NA	NA
3/16	3	3/8 - 24	NA	NA	NA
1/4	4	7/16 - 20	155-760	9/16 - 18	157-037
5/16	5	1/2 - 20	NA	NA	NA
3/8	6	9/16 - 18	155-705	11/16 - 16	157-038
1/2	8	3/4 - 16	155-706	13/16 - 16	157-039
5/8	10	7/8 - 14	155-707	1 - 14	157-040
3/4	12	1-1/16 - 12	155-709	1-3/16 - 12	157-017
7/8	14	1-3/16 - 12	155-747	NA	NA
1	16	1-5/16 - 12	155-748	1-7/16 - 12	155-714
1-1/4	20	1-5/8 - 12	155-702	1-11/16 - 12	NA
1-1/2	24	1-7/8 - 12	157-001	2 - 12	NA
2	32	2-1/2 - 12	NA	NA	NA
2-1/2	40	3 - 12	NA	NA	NA
3	48	3-1/2 - 12	NA	NA	NA

Thread size indicates the diameter of the threaded area in fractions of an inch and number of threads per inch.

NA = not a current CMW part numbered o-ring, or dash size does not occur in current CMW applications

SAE = straight thread fitting that seals by sandwiching a hard o-ring between a shoulder on the male part and an angular surface at the mouth of the female port.

ORS = o-ring face seal; a type of fitting that seals by compressing a hard, captive o-ring between two flat parallel faces, one grooved for the o-ring and the other plain to act as the sealing surface

P40/P80

Related Publications

Component	Ass'y	P/N
Model:		
P40/P80 Parts Manual		050-684
P40/P80 Operators Manual		054-451
P40/P80 Supplementary Maint. Guide		050-633
P40/P80 Power Pac Parts Manual		050-582
P40/P80 Power Pac Operator's Manual		054-416

Optional Kits

O-ring Repair Kit - FLG, ORS & SAE (15 different O-rings)	190-051
O-ring Repair Kit - Field Service (46 different O-rings)	190-052



Parts Manual Change Request

(Please print clearly)

Date: _____ Dealer No. (required): _____

Your Name: _____ Position: _____

Phone: _____ Fax: _____ E-mail: _____

Publication Information:

Parts Manual No.: _____ - _____ Model: _____

Illustration Part No.:	Manual Page No.:
1. _____ - _____	1. _____
2. _____ - _____	2. _____
3. _____ - _____	3. _____

Nature of Change Request:

- Text
 Graphics
 Missing Information

Describe change requested (if possible, include copy of publication page with changes marked.):

Please fax completed form to
Parts Manual Department (580) 572-3525

Thank you for taking the time to submit this request. We will contact you if further information is needed to process your request.

**A Note To
Ditch Witch
Equipment Owners:**

If your equipment was purchased through a Ditch Witch dealer, there is no need to read further.

However, if you purchased from any other source, please fill out the form on the reverse side and return it to us.

This will enable you to receive updates on this equipment as well as information on new products of interest.

Thanks for using Ditch Witch equipment.

(Please Fold Along This Line And Seal At Bottom With Tape)



**NO POSTAGE
NECESSARY
IF MAILED
IN THE
UNITED STATES**

BUSINESS REPLY MAIL
FIRST CLASS PERMIT NO 23 PERRY OKLAHOMA

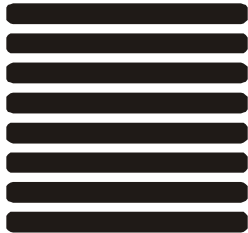

POSTAGE WILL BE PAID BY

**The Charles Machine Works, Inc.
P.O. Box 66
Perry, Oklahoma 73077-9989**



Ditch Witch® Registration Card

Please Type or Print All Information

Purchaser's Company Name

Attention

Street Address or P.O. Box

City County

State Zip Nation

()

Phone Number With Area Code

Model S rial Number

Attachments/Accessories Serial Numbers

Attachments/Accessories Serial Numbers

Attachments/Accessories Serial Numbers

Name of Ditch Witch Dealership

Your Signature